

Developmental & Intermediate Algebra Workbook

2nd edition, 2015

Dr. Shubhangi Stalder & Dr. Paul Martin



Reach high, for stars lie hidden in you.

Dream deep, for every dream precedes the goal.

Rabindranath Tagore

Developmental and Intermediate Algebra Workbook

Dr. Shubhangi Stalder

University of Wisconsin Waukesha

[*shubhangi.stalder@uwc.edu*](mailto:shubhangi.stalder@uwc.edu)

&

Dr. Paul Martin

University of Wisconsin Marathon

[*paul.martin@uwc.edu*](mailto:paul.martin@uwc.edu)

All material in this book is **copyrighted** to the authors and can only be used for non-profit educational purposes only. Please contact the authors for any other use.

About the authors

Dr. Shubhangi Stalder is a full professor of mathematics at the University of Wisconsin Waukesha. She has received her doctoral degree in mathematics from the University of Wisconsin Milwaukee in 1993. She has decades of teaching experience and her focus has always been to reach out to those who are



struggling in mathematics. Her main belief is that everyone can learn basic mathematics if they tried. The key is to understand the “Why” and the “How, and to be able to see the patterns across different mathematical processes. She believes that in the long run rote memorization does not work to learning mathematics. She uses yoga and meditation techniques with her students who experience math and test anxiety and continues to include mindfulness practice in her teaching of mathematics. She has received the UW System Board of Regents Teaching in Excellence Award (the state of Wisconsin’s highest

teaching award), the UW Colleges Chancellor’s Excellence in Teaching Award, and the UW Colleges Kaplan Teacher Award.

Dr. Paul Martin is a full professor of mathematics at the University of Wisconsin Marathon. He has received his doctoral degree in mathematics from the University of Wisconsin Madison in 1994. He has



decades of teaching experience and his focus has always been to bring to students how mathematics connects to the real world through building 3-dimensional models to collecting data. As a teacher, Martin stresses the importance of reasoning over memorization. He likes to present relevant ways of seeing and using mathematics and to show students its meaning. He tries to convey the importance of reasoning when doing mathematics. He has received several teaching awards over his career including the prestigious UW Colleges Chancellors Excellence in Teaching Award.

Acknowledgements

This book is partly based on a two year Developmental and Intermediate Algebra curricular redesign project funded by the UW-System Committee on Baccalaureate Expansion (COBE) grant. The material in this book is inspired by Sybilla Beckmann's work in her *Mathematics for Elementary Teachers* textbook.

The authors would like to thank their families who gave their professional opinions, their constant support and put up with long hours on this project (without their support it would have been difficult to put this book together in a such a short time).

We thank our teachers of mindfulness practice whose teachings helped us put in words our ideas on mindfulness practice in the learning of mathematics (special thanks to Dr. Paul Norton). A special thank you to Kris Luedke for his help.

The IT support we received was invaluable throughout all parts of the project, especially David Weber, Jenn Weber, Denise Spleas, and all the other IT staff at UW-Waukesha. Without their help the book and lectures would not exist.

We would also like to thank our chair Ed Stredulinsky who supported this project by getting us the grant funding and department funding for all the teacher training workshops through which this project evolved.

Lastly, we want to thank Kent Kromarek who was our sounding board for the nontraditional ideas presented in this book, for reviewing and editing the book. We would also like to thank Mark Fuller for his valuable contribution in editing the book. In addition, we want to thank all the brave souls (students and teachers) who were willing to give us their time in trying this material, and giving us their feedback to make this project better. We hope their work and ours has made it possible to get a product that we hope will be useful to other students and teachers.

Video Log Tracker

Please check the "Yes" box next to the appropriate video logs that you have successfully turned in. Make sure to turn in the cover page that appears for each section at the beginning of the class.

Item	Video Log #	Yes	Page #
1	Video Log 0.1		2
2	Video Log 1.1a		4
3	Video Log 1.2a		7
4	Video Log 1.2b		8
5	Video Log 1.3a		11
6	Video Log 1.4a		14
7	Video Log 1.4b		16
8	Video Log 1.5a		18
9	Video Log 1.5b		21
10	Video Log 1.5c		22
11	Video Log 1.6a		24
12	Video Log 1.6b		25
13	Video Log 1.7a		27
14	Video Log 1.7b		28
15	Video Log 1.7c		29
16	Video Log 1.8a		31
17	Video Log 1.8b		32
18	Video Log 1.8c		33
19	Video Log 1.8d		34
20	Video Log 1.9a		37
21	Video Log 1.9b		38
22	Video Log 1.9c		40
23	Video Log 1.10a		44
24	Video Log 2.1a		46
25	Video Log 2.1b		46
26	Video Log 2.1c		47
27	Video Log 2.1d		49
28	Video Log 2.1e		50
29	Video Log 2.1f		51
30	Video Log 2.2a		53
31	Video Log 2.2b		55
32	Video Log 2.2c		58
33	Video Log 2.3a		61
34	Video Log 2.3b		62
35	Video Log 2.3c		63
36	Video Log 2.3d		64
37	Video Log 2.3e		66
38	Video Log 2.4a		69
39	Video Log 2.4b		70
40	Video Log 2.4c		72
41	Video Log 2.4d		76
42	Video Log 2.4e		77
43	Video Log 2.4f		78
44	Video Log 2.5a		82

Item	Video Log #	Yes	Page #
45	Video Log 2.5b		83
46	Video Log 2.5c		84
47	Video Log 2.5d		85
48	Video Log 2.5e		88
49	Video Log 2.5f		89
50	Video Log 2.5g		90
51	Video Log 2.5h		93
52	Video Log 2.6a		96
53	Video Log 2.6b		97
54	Video Log 2.6c		99
55	Video Log 2.6d		101
56	Video Log 2.6e		103
57	Video Log 2.7a		106
58	Video Log 2.7b		108
59	Video Log 2.7c		110
60	Video Log 2.8a		114
61	Video Log 2.8b		116
62	Video Log 3.1a		119
63	Video Log 3.2a		122
64	Video Log 3.2b		130
65	Video Log 3.3a		134
66	Video Log 3.4a		138
67	Video Log 3.5a		142
68	Video Log 4.1a		148
69	Video Log 4.1b		151
70	Video Log 4.2a		153
71	Video Log 4.3a		158
72	Video Log 4.3b		160
73	Video Log 4.3c		162
74	Video Log 4.3d		164
75	Video Log 4.3e		172
76	Video Log 4.4a		176
77	Video Log 4.4b		178
78	Video Log 4.4c		180
79	Video Log 4.5a		184
80	Video Log 4.5b		186
81	Video Log 4.6a		190
82	Video Log 4.6b		192
83	Video Log 4.7a		194

0 Mindfulness of Learning Mathematics

Lectures

- 📺 Introduction To Authors http://www.youtube.com/watch?v=oShZs_1U0Xk (3 min)
- 📺 Introduction to Content <http://www.youtube.com/watch?v=SiXM29eUw2k> (3min)
- 📺 Introduction to the class and study skills <http://www.youtube.com/watch?v=th4cl8ugE-I> (11 min, video log 0.1)
- 📺 Introduction to the class and study skills <http://www.youtube.com/watch?v=I5OktRxH79c> (8 min, video log 0.1)
- 📺 Introduction to the class and study skills <http://www.youtube.com/watch?v=6WXLif0FVlc> (10 min, video log 0.1)

1. Please include a **summary** and **your detailed notes** from the lectures or e-text reading of this section. Failure to provide a summary and your notes could result in receiving a zero for this section.
2. List all the questions you had while watching the lectures or reading the e-text pages for this section. Do not just say “everything,” but please be specific and elaborate.

3. List all the video log questions on which you were stuck for this section. Do not just say “all,” but please be specific. Make sure you have attempted all the video log questions. You do not have to get them all correct. The attempt is what is important.

4. If using ALEKS, list all the topics on which you would like help.

Video Log 0.1

1. What does learning a subject mean to you?
2. Please write briefly in your own words what you think the following words mean to you-
 - a) **Mathematics**

 - b) **Problem**

 - c) **Mistakes**
3. How long do you think a student **SHOULD** wait to say “I don’t know” after reading a problem?
4. How long do you think you wait before you say “I don’t know” after reading a problem?
5. What strategies do you as a student use to solve a problem?

1.1 *A Brief History of Numbers*

Lecture

 Decimal Number System <https://www.youtube.com/watch?v=B6GA-o6YoLw> (12 min, video log 1.1a)

1. Please include a **summary** and **your detailed notes** from the lectures or e-text reading of this section. Failure to provide a summary and your notes could result in receiving a zero for this section.
2. List all the questions you had while watching the lectures or reading the e-text pages for this section. Do not just say “everything,” but please be specific and elaborate.

3. List all the video log questions on which you were stuck for this section. Do not just say “all,” but please be specific. Make sure you have attempted all the video log questions. You do not have to get them all correct. The attempt is what is important.

4. If using ALEKS, list all the topics on which you would like help.

Video Log 1.1a

1. Write the numbers below in expanded form.

a) 235

b) 4847

c) 5937303

d) 0.0072

e) 40.54

f) 400000

2. Write the numbers below.

a) Two hundred eight

b) Seventy thousand four hundred thirty-six

c) Five tenths

d) Eight million five thousand six hundred twenty-four

3. The numbers below are multiplied or divided by powers of ten. Write them as decimal numbers showing clearly where the decimal point moves to.

a) 375.87×100000

b) 0.00458×10

c) 7×100

d) $117 \div 100$

e) $375.87 \div 10000$

f) $0.0458 \div 100$

4. Write the place value of each of the nonzero digits that appear in the numbers below.

a) 235

b) 4837

c) 5937208

d) 40.56

5. How would you write a check for \$450.67 to Best American where you bought your TV?

1.2 Number Sets

Lecture

 Natural through Complex Numbers <http://www.youtube.com/watch?v=MH946PzUGlg> (13 min, video log 1.2 a, b)

1. Please include a **summary** and **your detailed notes** from the lectures or e-text reading of this section. Failure to provide a summary and your notes could result in receiving a zero for this section.
2. List all the questions you had while watching the lectures or reading the e-text pages for this section. Do not just say “everything,” but please be specific and elaborate.

3. List all the video log questions on which you were stuck for this section. Do not just say “all,” but please be specific. Make sure you have attempted all the video log questions. You do not have to get them all correct. The attempt is what is important.

4. If using ALEKS, list all the topics on which you would like help.

Video Log 1.2a

Project

After you have learned the names of all the numbers we have studied so far, pay attention to the real world that you live in and keep track of all the places and things where you see numbers. Numbers can appear in the many places like the fruits and vegetables you eat, barcodes on different products are also numbers in a disguised form, Highways, different parts in your cars, and nutrition labels on food products. So be observant and see where numbers appear in your life in the hours after you exit the classroom today and before you return the next class. Write the number you saw and the context or story behind the number (what information did the number give you) and the type of number ($N, W, Z, Q, \bar{Q}, R, C$) in the table below.

	Numbers	Context (i.e., where the number appeared or the story behind it)
1.		
2.		
3.		
4.		
5.		
6.		
7.		
8.		
9.		
10.		
11.		
12.		
13.		
14.		
15.		

Video Log 1.2b

1. List at least two rational numbers and two irrational numbers between 3.3 and 3.4
- 2. List at least two rational numbers and two irrational numbers between -3.3 and -3.4**
3. List, if possible, what number would be considered to be the smallest counting number.
4. List, if possible, what number would be considered to be the smallest whole number.
- 5. List, if possible, what number would be considered to be the smallest integer number.**
- 6. List if, possible, what number would be considered to be the smallest rational number.**
7. List if, possible, what number would be considered to be the smallest irrational number.
8. List, if possible, what number would be considered to be the smallest real number.
- 9. List, if possible, an integer between -34 and -33 .**
10. List, if possible, a rational and an irrational number between $2.313113111 \dots$ and $2.323223222 \dots$

11. Answer true or false and justify your answer

- a. 0 is a rational number

- b. $\frac{2}{0}$ is a rational number

- c. 0 is an irrational number

- d. 0 is a complex number

- e. -4 is an complex number

12.	For each column check all the labels that apply.	-35	-2i	$\frac{17}{43}$	5.41441 ...	$9 - 5.3i$	$\sqrt{9} = 3$	$\sqrt{11}$	-58.4	$5.0\overline{47}$
	a. Whole Number									
	b. Integer									
	c. Rational									
	Irrational									
	d. Real Number									
	e. Complex Number									





1.3 Geometric Shapes

Lecture

 Geometry <http://www.youtube.com/watch?v=X4v0CZzC9ec> (10 min, video log 1.3a)

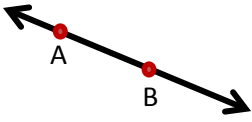
1. Please include a **summary** and **your detailed notes** from the lectures or e-text reading of this section. Failure to provide a summary and your notes could result in receiving a zero for this section.
2. List all the questions you had while watching the lectures or reading the e-text pages for this section. Do not just say “everything,” but please be specific and elaborate.
3. List all the video log questions on which you were stuck for this section. Do not just say “all,” but please be specific. Make sure you have attempted all the video log questions. You do not have to get them all correct. The attempt is what is important.
4. If using ALEKS, list all the topics on which you would like help.

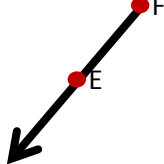
Video Log 1.3a

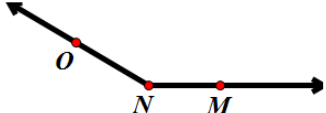
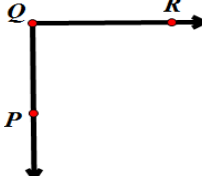
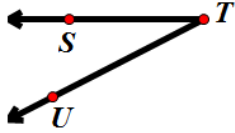
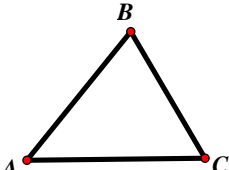
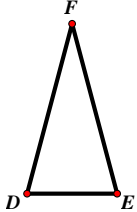
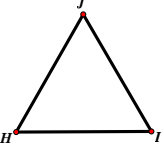
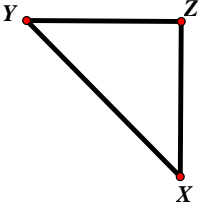
1.	Identify the objects below as a line, a ray, or a line segment. Use appropriate notation to describe the object.			
				
3.	Identify the angles below as an acute angle, obtuse angle, or right angle.			
	 <p>$m\angle MNO = 149.42^\circ$</p>	 <p>$m\angle PQR = 90.00^\circ$</p>	 <p>$m\angle STU = 27.52^\circ$</p>	
3.	Identify the triangles below as scalene, acute, obtuse, or right. If possible also identify them as an equilateral triangle, or an isosceles triangle.			
	 <p> $m\angle BAC = 50.35^\circ$ $m\angle BCA = 60.17^\circ$ $m\angle ABC = 69.48^\circ$ </p>	 <p> $m\overline{DF} = 5.56\text{ cm}$ $m\overline{FE} = 5.56\text{ cm}$ $m\overline{DE} = 2.86\text{ cm}$ </p>	 <p> $m\overline{JH} = 5.74\text{ cm}$ $m\overline{IJ} = 5.74\text{ cm}$ $m\overline{HI} = 5.74\text{ cm}$ </p>	 <p> $m\angle YZX = 90.00^\circ$ $m\overline{YZ} = 4.18\text{ cm}$ $m\overline{ZX} = 4.18\text{ cm}$ $m\overline{YX} = 5.91\text{ cm}$ </p>

4. Identify the quadrilaterals below as a rectangle, square, or a trapezoid.

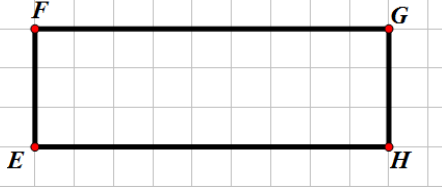
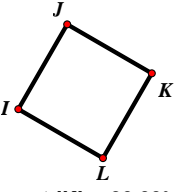
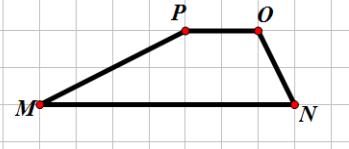
	 <p> $m\angle JKL = 90.00^\circ$ $m\angle KLI = 90.00^\circ$ $m\angle LIJ = 90.00^\circ$ $m\angle IJK = 90.00^\circ$ $m\overline{IJ} = 3.00 \text{ cm}$ $m\overline{JK} = 3.00 \text{ cm}$ $m\overline{KL} = 3.00 \text{ cm}$ $m\overline{LI} = 3.00 \text{ cm}$ </p>	
---	---	---

5. Determine if the lines below are parallel, perpendicular, or neither.

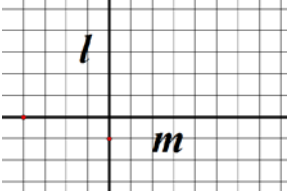
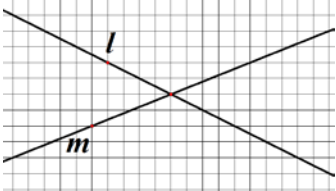
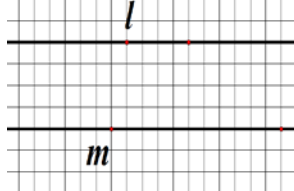
		
---	--	--

6. a. List all the pairs of alternate interior angles from the angles below.
 b. List all the pairs of alternate exterior angles from the angles below.
 c. List all the pairs of corresponding angles from the angles below.

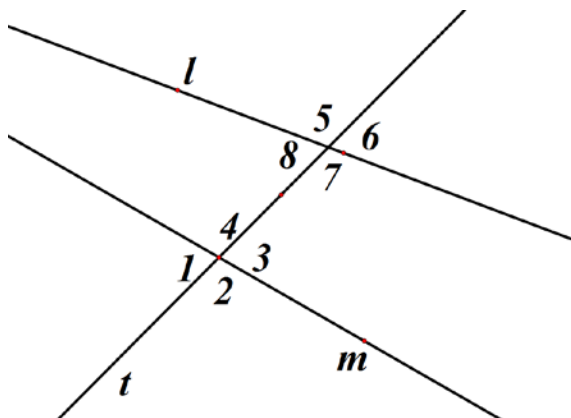

7. What is the measure of the complementary angle to 40° ?
 8. What is the measure of the supplementary angle to 80° ?

1.4 Visualizations of Rational and Decimal Numbers

Lectures

 One Visualization of Rational numbers

<http://www.youtube.com/watch?v=79ZjO2MTiOc> (11 min, video log 1.4a)

 Equivalent Fractions <http://www.youtube.com/watch?v=xruSTzZcpns> (11 min, video log 1.4a)

 Ratios and Percents' http://www.youtube.com/watch?v=Z5JYj_FQx7M (15 min, video log 1.4a)

 Ordering Numbers <http://www.youtube.com/watch?v=Wjcel8TB4mg> (8min, video log 1.4b)

1. Please include a **summary** and **your detailed notes** from the lectures or e-text reading of this section. Failure to provide a summary and your notes could result in receiving a zero for this section.
2. List all the questions you had while watching the lectures or reading the e-text pages for this section. Do not just say “everything,” but please be specific and elaborate.
3. List all the video log questions on which you were stuck for this section. Do not just say “all,” but please be specific. Make sure you have attempted all the video log questions. You do not have to get them all correct. The attempt is what is important.
4. If using ALEKS, list all the topics on which you would like help.

Video Log 1.4a

1. What percentage of the picture below is shaded if the entire picture represents 100%?

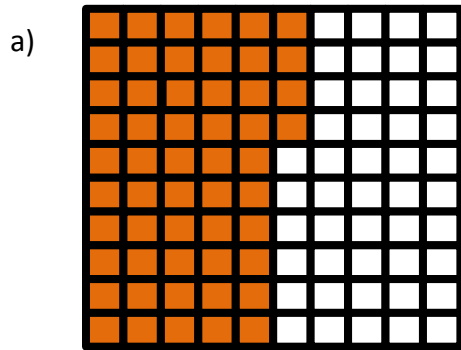

2. What percentage does the shaded part in each picture below represent? The whole is marked clearly in each picture so be careful in how you answer.

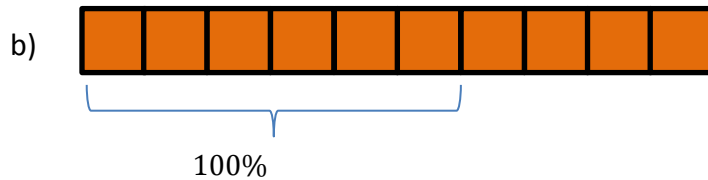
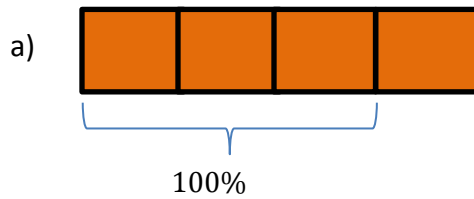

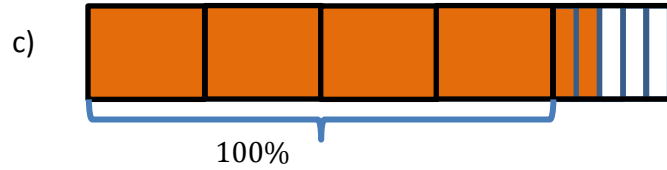

3. Draw a strip diagram to represent the percentages below. If there are multiple ways to represent a percentage, then show all equivalent diagrams representing the percentage.

a) **35%**

b) 40%

c) 15%

d) 125%

e) $66.\bar{6}\%$

4. Convert the percentages below to decimal numbers.

a) 78%

b) 0.5%

c) 745%

5. Convert each decimal number below to a percentage.

a) 89.4

b) 0.027

c) 0.0092

Video Log 1.4b

Write numbers below in descending order (largest to smallest).

1. 9987, 10,012, 8,999

2. $\frac{4}{13}$ and $\frac{1}{3}$

3. $-2\frac{3}{4}$, $-2\frac{9}{13}$, $-3\frac{1}{10}$

4. 3, 3.458, 3.45.

5. -15.75, -315.95

6. -1.07, -73.81, 2.34, 2.078.

Use the appropriate sign $<$, $>$, or $=$, to make the statements below a true statement.

7. -23.5 _____ -2.5

8. **0.002** _____ **0.0025**

9. 456.89 _____ 4.5689

10. **223.7** _____ $\frac{2237}{10}$

1.5 Representing Real Numbers on a Number Line and Complex Numbers in the Complex Plane

Lecture

 Plotting Numbers on a Number Line

<http://www.youtube.com/watch?v=BohmHn8NgOA> (14 min, video log 1.5a and 1.5b)

 Scientific Notation

<http://www.youtube.com/watch?v=4lM8zwi0kWY> (10 min, video log 1.5c)

1. Please include a **summary** and **your detailed notes** from the lectures or e-text reading of this section. Failure to provide a summary and your notes could result in receiving a zero for this section.
2. List all the questions you had while watching the lectures or reading the e-text pages for this section. Do not just say “everything,” but please be specific and elaborate.
3. List all the video log questions on which you were stuck for this section. Do not just say “all,” but please be specific. Make sure you have attempted all the video log questions. You do not have to get them all correct. The attempt is what is important.
4. If using ALEKS, list all the topics on which you would like help.

Video Log 1.5a

1. Plot -3.15 and -3.115 on the same number line.
2. Plot 5 and 5000 on the same number line.
3. Plot $\frac{4}{5}$, $\frac{2}{5}$, and $-1\frac{2}{5}$ on the same number line.
4. Plot $\frac{2}{3}$, $-\frac{1}{6}$, and $3\frac{1}{2}$ on the same number line.
5. Plot $-\frac{4}{7}$, $-\frac{12}{7}$, and $-\frac{15}{7}$ on the same number line.
6. Plot $\frac{11\pi}{6}$, $\frac{5\pi}{6}$, $-\frac{3\pi}{6}$, and $-\frac{7\pi}{6}$ and π on the same number line. (Use $\pi/6$ as the increment.)

7. For each of the number line positions marked with arrows below, determine its decimal or fraction as a mixed number representation.

a.

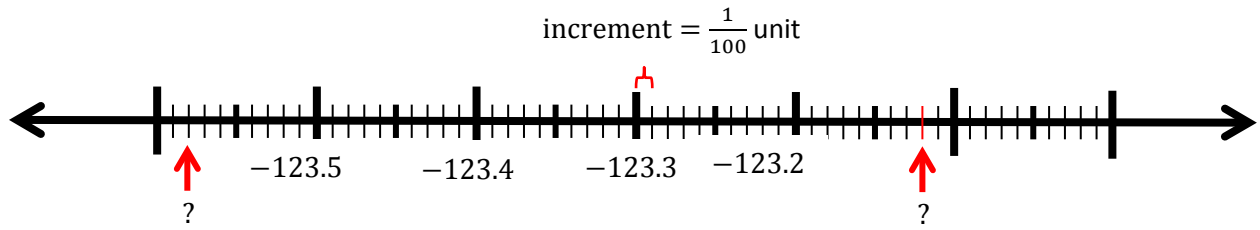

b.

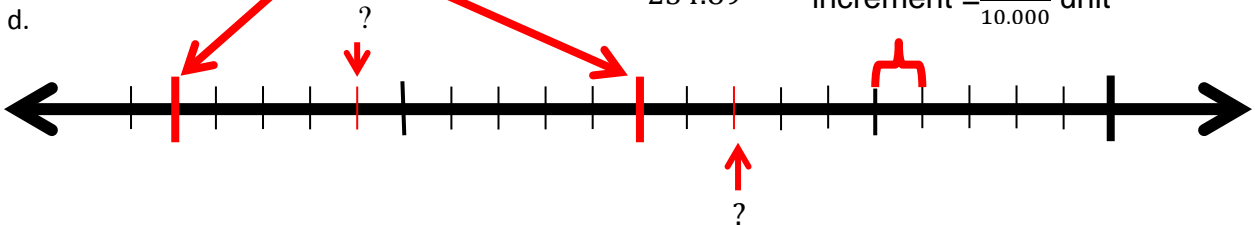
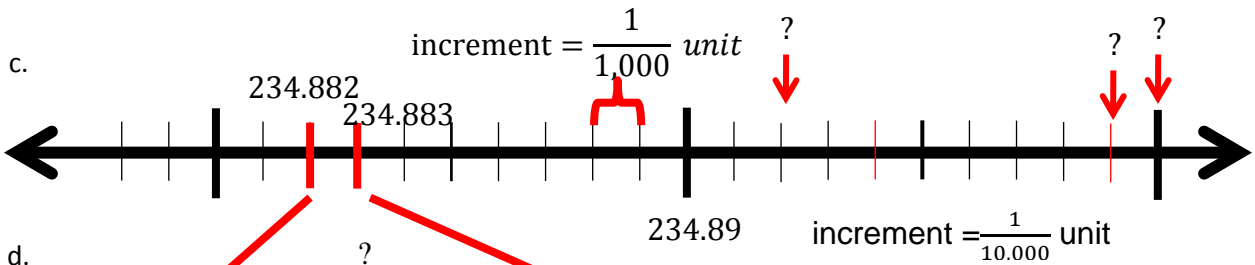
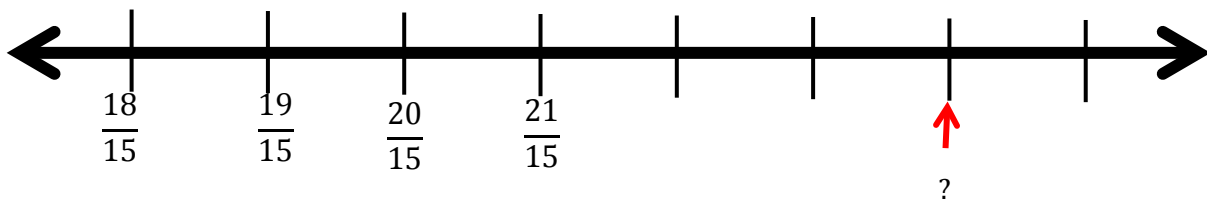

e.

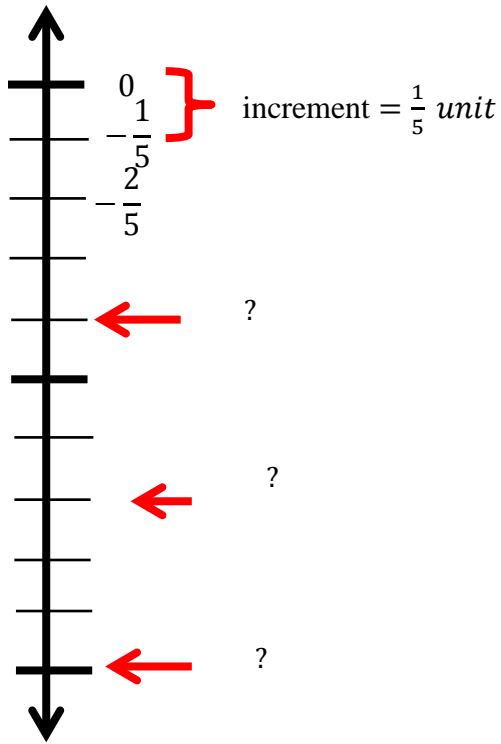

Video Log 1.5 b

Plot the complex numbers below

a. $-4 - 2i$

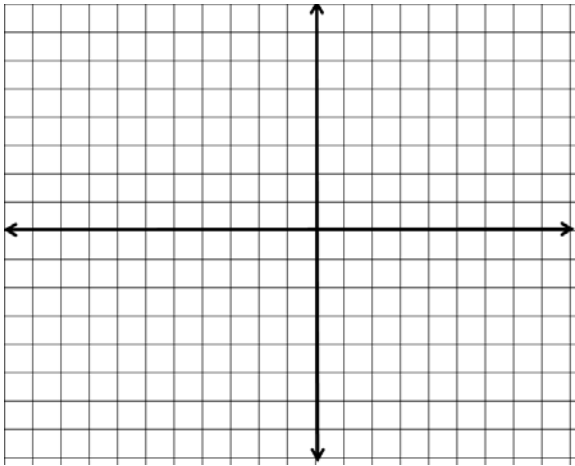

c. $-3i$

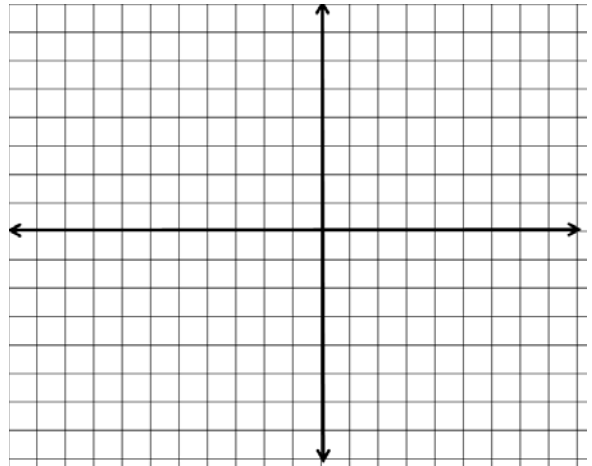

b. 3

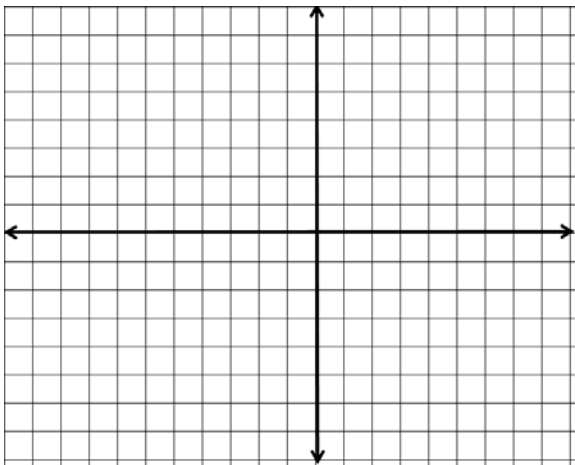

d. $-2 + 3i$

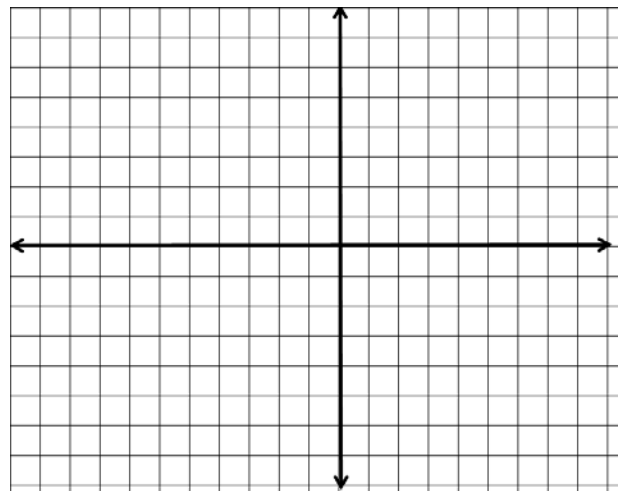

Video Log 1.5c

1. Write the following two numbers in Scientific Notation

- a. 450.1297

- b. 0.009075

2. Write the following two numbers in Decimal Notation

- a. 1.0087×10^8

- b. 7.89×10^{-6}

3. **If your favorite Granola bar or Candy bar says it has 0 gm. of Trans fats, do you think that is accurate? If not, what could be the case? Explain.**

4. While you are driving, your car's digital speedometer reads 25 mph. Do you think that the speed is exactly 25 mph? What factors should you be aware of? What kind of rounding is taking place?

5. How do you interpret a bathroom scale reading of 135.6 lbs., when the scale only displays the last digit as an even number?

1.6 Natural Number Exponents and Properties of Exponents

Lectures

 Exponents http://www.youtube.com/watch?v=QlnQTDKNH_Q (9 min, video log 1.6a)

 Product Rule of Exponents <http://www.youtube.com/watch?v=qS2yuBEXcxk> (9 min, video log 1.6a)

 Quotient Rule of Exponents <http://www.youtube.com/watch?v=SgEy7s1Vcw> (5 min, video log 1.6b)

1. Please include a **summary** and **your detailed notes** from the lectures or e-text reading of this section. Failure to provide a summary and your notes could result in receiving a zero for this section.
2. List all the questions you had while watching the lectures or reading the e-text pages for this section. Do not just say “everything,” but please be specific and elaborate.
3. List all the video log questions on which you were stuck for this section. Do not just say “all,” but please be specific. Make sure you have attempted all the video log questions. You do not have to get them all correct. The attempt is what is important.
4. If using ALEKS, list all the topics on which you would like help.

Video Log 1.6a

Use the patterns observed above to write each expression in the form of one base raised to one exponent or in the form a^n . Remember what the base and exponent's meanings are before writing the answer.

1. $\left(\frac{2}{3}\right)^3 \left(\frac{2}{3}\right)^5$

8. $\left(\frac{1}{3}\right)^2 \left(\frac{1}{3}\right)^7$

2. $(3x - 2)^5(3x - 2)^4$

9. $5^{14}5^3$

3. $-(c^2c^3)^4$

10. $(-b)^{10}(-b)^{12}$

4. $(3^23^5)^2$

11. $(-7a)^2(-7a)^{11}$

5. $\left(-\frac{x+1}{y}\right)^6 \left(-\frac{x+1}{y}\right)^5$

12. $(g(x))^4(g(x))^3$

6. $(x^5)^3$

13. $((2x + 4)^4)^3$

7. $(5^4)^3$

14. $(3.5^2)^4$

Video Log 1.6b

For all the problems use the patterns observed above to write the answer in the form of one base raised to one exponent or in the form a^n . The convention is that $a^2a^3 = a^2 \times a^3 = a^5$. Remember what the base and exponent's meanings are before writing the answer.

1. $\frac{5^{14}}{5^3}$

2. $\frac{(-7a)^{11}}{(-7a)^2}$

3. $\frac{(3x - 2)^5}{(3x - 2)^4}$

4. $\frac{(a + b)^3}{(a + b)^2}$

5. $\frac{(g(x))^7}{(g(x))^3}$

6. $\frac{(-b)^{15}}{(-b)^3}$

7. $\left(\frac{2^{10}}{2^4}\right)^3$

8. $\left(\frac{x^6}{x^2}\right)^3$

9. $-\left(\frac{c^{13}}{c^3}\right)^2$

1.7 Negative and zero exponents

Lecture

 Zero and Negative Exponents

http://www.youtube.com/watch?v=3_pnpRr93hA (14 min, video log 1.7a, b, c)

1. Please include a **summary** and **your detailed notes** from the lectures or e-text reading of this section. Failure to provide a summary and your notes could result in receiving a zero for this section.
2. List all the questions you had while watching the lectures or reading the e-text pages for this section. Do not just say “everything,” but please be specific and elaborate.

3. List all the video log questions on which you were stuck for this section. Do not just say “all,” but please be specific. Make sure you have attempted all the video log questions. You do not have to get them all correct. The attempt is what is important.

4. If using ALEKS, list all the topics on which you would like help.

Video Log 1.7a

For each problem, write down base=__ and exponent=__. If there are multiple bases and exponents, write all of them.

		Base/s	Exponent/s
1.	$-\left(\frac{2}{3}\right)^{-2}$		
2.	$(g(x))^{-4}$		
3.	$\left(-\frac{1}{3}\right)^{-5}$		
4.	$-(c^2d^{-3})^{-4}$		
5.	$(a + b)^{-7}$		
6.	$-\left(-\frac{x + 1}{y}\right)^{-2}$		
7.	5^{-4}		
8.	$(-7)^{-2}$		
9.	$(-b)^{-12}$		
10.	$-(-7)^{-9}$		

Video Log 1.7b

For all the problems use the patterns observed so far to write the answer without any negative exponents in the form a^n or $\frac{1}{a^n}$, where n is a counting number, and a is the base. For example, -4^{-12} , could be written as $-4^{-12} = -\frac{1}{4^{12}}$; whereas $\frac{(f(x))^{-3}}{(f(x))^5}$, could be written as $\frac{(f(x))^{-3}}{(f(x))^5} = (f(x))^{-3-5} = (f(x))^{-8} = \frac{1}{(f(x))^8}$. Remember to show all your reasoning. Assume that all variables are such that in the final answer the denominators end up being nonzero real numbers.

1. -3^{-2}

10. $-\left(\frac{c^{-3}}{c^{13}}\right)^2$

2. $(-3)^{-2}$

11. $\frac{(a+b)^2}{(a+b)^3}$

3. a^{-7}

12. $\frac{(g(x))^{-7}}{(g(x))^3}$

4. 2^{-4}

13. $\frac{(3x-2)^4}{(3x-2)^{-5}}$

5. $(2^{-4})^{-3}$

14. $\frac{(-7a)^{-11}}{(-7a)^2}$

6. $\frac{1}{5^{-14}}$

15. $(temp(x))^{-5}$

7. $\frac{5^3}{5^{-14}}$

16. $\frac{(-b)^{-3}}{(-b)^{12}}$

8. $(-3^{-5})^2$

9. $\left(\frac{x^2}{x^{-6}}\right)^3$

Video Log 1.7c

Simplify each exponential expression using the properties of exponents. Write your answers without any negative exponents in the form a^n or $\frac{1}{a^n}$, where n is a counting number.

1. $2^3 \times 2^5$

9. $\frac{4^9}{4^3}$

2. $3^{10} \times 3^2$

10. $\frac{x^9}{x^5}$

3. $(-5)^3 \times (-5)^4$

11. $-\left(\frac{1234567}{10496768}\right)^0$

4. $7.3^2 \times 7.3^3$

12. $\frac{1}{-2^{-3}}$

5. $-a^3 \times a^5$

13. $2^{-3} \times 2^5$

6. $c^{10} \times c^2$

14. $-\frac{x^{-9}}{x^{-5}}$

7. $(6^2)^4$

15. $(-2^4)^{-3}$

8. $(-x^2)^5$

16. $\left(\frac{a^{-4}}{a^3}\right)^{-2}$

1.8 Rational Exponents and Radicals

Lecture

 Rational Exponents <http://www.youtube.com/watch?v=GJVtvQ2bm8M> (13 min, video log 1.8a)

 Radical Notation <http://www.youtube.com/watch?v=B0zdWX3CzFE> (8 min, video log 1.6b, c)

 Estimating Radicals <http://www.youtube.com/watch?v=hMWQUtQuTKI> (5 min, video log 1.8d)

1. Please include a **summary** and **your detailed notes** from the lectures or e-text reading of this section. Failure to provide a summary and your notes could result in receiving a zero for this section.
2. List all the questions you had while watching the lectures or reading the e-text pages for this section. Do not just say “everything,” but please be specific and elaborate.

3. List all the video log questions on which you were stuck for this section. Do not just say “all,” but please be specific. Make sure you have attempted all the video log questions. You do not have to get them all correct. The attempt is what is important.

4. If using ALEKS, list all the topics on which you would like help.

Video Log 1.8a

Evaluate each of the exponential expressions

1. $25^{\frac{1}{2}}$

2. $27^{\frac{1}{3}}$

3. $49^{\frac{1}{2}}$

4. $(-8)^{\frac{1}{3}}$

Simplify to a base raised to a natural number times a base to a proper fraction.

5. $3^{\frac{6}{5}}$

6. $32^{\frac{1}{3}}$ (Note that $32 = 2^5$.)

7. $y^{\frac{23}{3}}$

Video Log 1.8b

Identify the radicand, and the index in the radical expressions below, and write in words how you would read the expression.

		Radicand	Index	How to read it
1.	$\sqrt[2]{a+b}$			
2.	$\sqrt[3]{g(x)}$			
3.	$\sqrt[5]{-b}$			
4.	$\sqrt{6}$			
5.	$-\frac{1}{\sqrt[6]{12}}$			
6.	$\sqrt[3]{225}$			
7.	$\sqrt[5]{\frac{1}{7}}$			
8.	$\sqrt{3x}$			
9.	$3\sqrt{x}$			

Video Log 1.8c

Rewrite the exponential notation using the radical notation

1. $5^{\frac{4}{3}}$

2. $x^{-\frac{1}{5}}$

3. $(3 + 5x)^{\frac{1}{7}}$

4. $(ab)^{\frac{1}{3}}$

5. $5^{\frac{11}{3}}$

6. $4^{-1/3}$

Rewrite the radical notation using the exponential notation

7. $\sqrt[5]{7}$

8. $\frac{1}{\sqrt[5]{a}}$

9. $\sqrt{4 + 9a}$

10. $\sqrt[3]{ab}$

11. $\sqrt[3]{2^{11}}$

12. $-\sqrt{5}$

Video Log 1.8d

Evaluate the following. Your final answer should be without an exponent or a radical. Assume all variables are nonzero positive real numbers.

1. $\sqrt{9}$

2. $\sqrt{10000}$

3. $\sqrt{400}$

4. $\frac{1}{\sqrt[3]{27}}$

5. $\sqrt[5]{b^5}$

6. $-\sqrt{36}$

7. $-\frac{1}{\sqrt{4}}$

8. $\sqrt{-9}$

Find the tenths place digit of each radical below.

9. $\sqrt{7}$

10. $\sqrt[3]{25}$

11. $\sqrt{10}$

12. For each number in the left column, state whether it is less than, equal to, or greater than the number at the top of each column. Follow the example in the first row.

	$\frac{1}{2^2}$	2^3	-2^2	$\frac{1}{\sqrt{2}}$	$4\sqrt{2}$	$-\frac{1}{2^{-\frac{1}{2}}}$
$\sqrt{2}$	=	<	>	>	<	>
$\frac{1}{2^2}$						
-4						
4						
$\sqrt{32}$						
$2^{-\frac{1}{2}}$						
$\frac{1}{2^{-\frac{1}{2}}}$						
$-\sqrt{2}$						

1.9 Polynomials

Lecture

 Polynomials <https://www.youtube.com/watch?v=GjpAlev8o8E> (14 min, video log 1.9a)

 Translating Words Part 1 <http://www.youtube.com/watch?v=Ff-bOPs5iz4> (13 min, video log 1.9b ,c)

 Translating Words Part 2 http://www.youtube.com/watch?v=xVKV_9OsNeQ (6 min, video log 1.9b ,c)

1. Please include a **summary** and **your detailed notes** from the lectures or e-text reading of this section. Failure to provide a summary and your notes could result in receiving a zero for this section.
2. List all the questions you had while watching the lectures or reading the e-text pages for this section. Do not just say “everything,” but please be specific and elaborate.

3. List all the video log questions on which you were stuck for this section. Do not just say “all,” but please be specific. Make sure you have attempted all the video log questions. You do not have to get them all correct. The attempt is what is important.

4. If using ALEKS, list all the topics on which you would like help.

Video Log 1.9a

Answer whether the algebraic expressions below are polynomials or rational expressions. If the expression is a polynomial find the degree of the polynomial.

1. $\sqrt{2} - 5x^{-2} + 10x - 15x^2$

2. $\frac{3x-1}{x^2-4}$

3. $\sqrt{x} - \frac{3}{4}x^{12} + 10x - 15x^2$

4. $6.1x^3y^2 - \frac{x^6}{5} + 7$

5. $-5t^{21} + 10t - 15$

6. $6.1s^3r^2 - \frac{x^6}{5r^5} + 7r$

Video Log 1.9b

Write an expression for each of the situations in examples below.

1. The length of a rectangle is two more than the width. Express the value of the length in terms of the width w .
2. The sale price of the shirt is 25% off of the regular price. Express the sale price in terms of the regular price R .
3. The price of gasoline increased by 15% from 2012 to 2013. Express the amount of the increase per gallon in terms of C which represents the 2012 cost of a gallon.
4. Write an expression for the perimeter of the polygon in terms of x , and y .

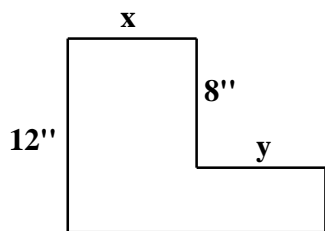

5. Sue walked for two thirds of the distance of the whole race. Express the distance Sue walked in terms of the total length of the race L .
6. The current price of a quart of maple syrup is 35% more than it was in 2008. Express the current price of maple syrup in terms of the 2008 price of M dollars per quart.
7. Joe Bikes at least ten miles more than twice the distance he runs each week. Express this as an inequality where B and R represent the number of miles Joe bikes and runs each week.

8. A 48 inch plank has x inches cut off of it. Express the length of the plank remaining in terms of x .

9. Express as an algebraic expression. The product of eight more than a **number** and 11. Use x to represent the **number**.

10. Jean has \$120 dollars to spend on food for a party. Give an expression for how much she has yet to spend after paying x dollars at the local Deli.

11. Jim is 5 years older than Bob and Karl is half of Bob's age. Write an expression for the sum of the three men's ages in terms of Bob's age B .

12. Glenn is two years younger than his brother Bob. Give an expression for Glenn's age in terms of Bob's age B .

Video Log 1.9c

Find the following

1. Find the perimeter of the polygon.

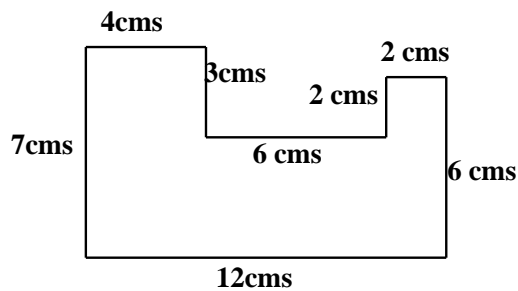

2. Find the perimeter of a house that is 30 feet wide and 50 feet long.
3. Find the circumference of a race track that has the shape of a circle with a diameter of 200 feet. Use 3.14 as an approximation for π . Round your answers to the nearest tenth of a foot.
4. Find the area occupied by a house that is 50 feet long and 32 feet wide.
5. Find the area of a baseball diamond which is a square with side length of 90 feet.

6. Find the area of the parallelogram.

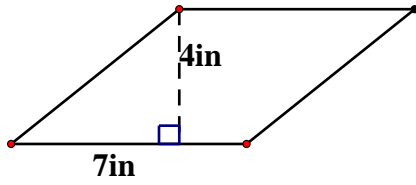

7. Find the area of the triangle.

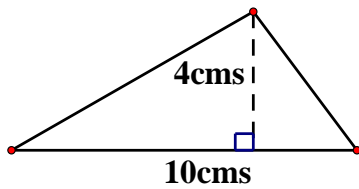

8. Find the area of the trapezoid.

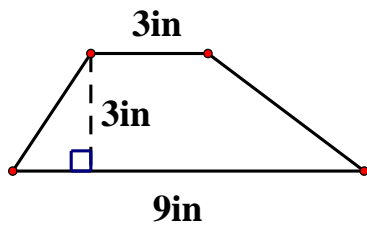

9. Find the surface area and volume of a matchbox (shaped as a rectangular prism) that is 2cms by 4cms by 5cms.

10. Find the volume of a model pyramid that has a square base of 4feet by 4feet and is 6 feet tall.
11. Find the volume of a conical pile of sand (sand pile in shape of an inverted cone) that has a base diameter of 6 feet and is 2 feet tall. Use 3.14 as an approximation for π . Round your answers to the nearest tenth of a cubic foot.
12. Find the volume of a grapefruit with diameter of 9 cm. Assume that a grapefruit is a perfect sphere. Use 3.14 as an approximation for π . Round your answers to the nearest tenth of a cubic cm.
13. Find the volume and total surface area of a cylindrical pontoon that is two feet in diameter and 20 feet long.
14. A rectangular swimming pool is 30 feet long and 15 feet wide. A contractor is to replace a ceramic tile deck that is six feet wide surrounding the pool. Determine how many square feet of decking material is needed.

1.10 Functions

Lecture

 Introduction to Functions <http://www.youtube.com/watch?v=GHR4QiPoBi8> (11 min, video log 1.10a)

1. Please include a **summary** and **your detailed notes** from the lectures or e-text reading of this section. Failure to provide a summary and your notes could result in receiving a zero for this section.
2. List all the questions you had while watching the lectures or reading the e-text pages for this section. Do not just say “everything,” but please be specific and elaborate.
3. List all the video log questions on which you were stuck for this section. Do not just say “all,” but please be specific. Make sure you have attempted all the video log questions. You do not have to get them all correct. The attempt is what is important.
4. If using ALEKS, list all the topics on which you would like help.

Video Log 1.10a

1. Given that $f(x) = 3x + 1$, $g(t) = \sqrt{5}$, $R(s) = \frac{3s+4}{s-6}$, and $h(a) = \sqrt[3]{a}$, find the value of
- $f(5)$
 - $g(100)$
 - $f(a)$
 - $R(1)$
 - $-h(8)$
 - $h(1)$
 - $g(-5)$
 - $R(0)$
 - $f(a + h)$

Extra Credit

- Can you think of a function $f(x)$ for which no matter what x is the output is always 1? What would that function's rule look like?
- Can you think of a function $g(x)$ so that for any two real numbers a , and b , if $a < b$, then $g(a) < g(b)$?
- Can you think of a function $h(x)$ so that for any two real numbers a , and b , if $a < b$, then $h(a) > h(b)$?

2.1 Addition as Combining “Like” units

Lecture

 Identifying Like Units <http://www.youtube.com/watch?v=Zqzb5VpogNs> (6 min, video log 2.1a, video log 2.1b)

 Properties of Addition and Introduction to Adding Decimal Numbers
<http://www.youtube.com/watch?v=b12XsziOpJA> (10 min, video log 2.1c)

 Addition of Decimal Numbers, Polynomials, Radical Expressions, and Functions
http://www.youtube.com/watch?v=Xwwy9_-NQ0M (14 min, video log 2.1d,e)

 Introduction to Addition of Fractions and Rational Expressions
http://www.youtube.com/watch?v=y_LvHKSC10E (9 min, video log 2.1f)

1. Please include a **summary** and **your detailed notes** from the lectures or e-text reading of this section. Failure to provide a summary and your notes could result in receiving a zero for this section.
2. List all the questions you had while watching the lectures or reading the e-text pages for this section. Do not just say “everything,” but please be specific and elaborate.

3. List all the video log questions on which you were stuck for this section. Do not just say “all,” but please be specific. Make sure you have attempted all the video log questions. You do not have to get them all correct. The attempt is what is important.

4. If using ALEKS, list all the topics on which you would like help.

Video Log 2.1a

Answer true or false

1. $5in + 3in = 8$
2. $5in + 3 = 8$
3. $5in + 3in + 7in = 15in$
4. $5ft + 3in + 4in = 12$
5. $5ft + 3in + 4in = 60in + 3in + 4in = 67in$

Video Log 2.1b

Below are 4 different sets of objects. For each set of objects create groups as shown in the practice problem, where the objects in one group all share the same unit. Specify the unit for each group as shown in the practice example above.

1. Set 2

$$\frac{5}{\sqrt{x}}, 3 + 2i, 5x^3, 2\sqrt{x}, 5^3\sqrt{x}, \frac{7}{x^{-3}}, \frac{2}{x-3}, 4\sqrt{x-3}, \frac{6}{x^{-\frac{1}{2}}}, \frac{5}{x+3}, 5(x-3)^{\frac{1}{2}},$$
$$5\sqrt{x} - 5\sqrt{3}, \frac{4}{x} - \frac{2}{3}, 7^3\sqrt{x-3}, 9x^{-\frac{1}{2}}, \frac{9}{x^{-3}}, 11(x-3)^{-1}, 5 + 7i$$

2. Set 3

$$5g(x), f(x), 5g(a), 7g(a^2), f(a+h), f(a)+f(h), f(2x), 3\sin(x), 5f(2x),$$
$$3f(x), \sin(2x), 4g(a), 12f(a), 2f(x), (g(a))^2,$$
$$5f(a) + 5f(h), 5f(a+h), 3(g(a))^2, 5f(x), g(a^2), 5\sin(2x), 2\sin(x), 3f(a+h)$$

3. Set 4

2cm , 5km , 3m , 4.3in^2 , 5km^2 , 2cm^2 , $\$4$, 5gm , 7yd , 500cm ,
 4.3in , 6m^3 , 11.2km , 3mi , 12in , 4cm , 15ft , 4kg , 5.12gm , 12lb ,
 187in , 2ft , 27.9cm^2 , $\$89.99$, 65km , 65km^2

4. Set 5

$32x$, $3x^2$, $(x + y)^2$, $\sqrt{x^2 + y^2}$, $x + y$, $x^2 + y^2$, $2\sqrt{x} + 2$, $(x - y)^2$,
 $\frac{5}{x^2}$, $x^{\frac{1}{2}} + y^{\frac{1}{2}}$, $\sqrt{x + y}$, $2x^{\frac{1}{2}} + 2$, $x^2 + y^2$, $\sqrt{x} + \sqrt{y}$

Video Log 2.1c

1. What is the largest number you could get from adding two single digit numbers?
2. Can there be a carryover of more than 1? Explain why or why not.
3. Jen worked $2\text{ hr } 45\text{ min}$ at the library and $3\text{ hr } 20\text{ min}$ as a hotel receptionist and $1\text{ hr } 15\text{ min}$ as a lifeguard. What is the total number of hours and minutes she worked?

4. State the property of addition that justifies each statement.

a. $y + (3 + x) = y + (x + 3)$

b. Getting a free item at the grocery store does not change the total bill.

c. $3\sqrt{x} + (4\sqrt{x} + 3) = (3\sqrt{x} + 4\sqrt{x}) + 3$

5. Find the perimeter of a track that consists two horizontal segments of 100 yards and two semicircular portions each of diameter 100 yards as shown in the picture. Use a calculator and use 3.14 as an approximation of π . Recall that a circles perimeter or circumference is given by $C = 2\pi r = \pi D$.

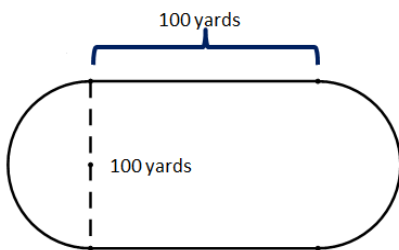

Video Log 2.1d

Perform the additions below without using a calculator. Pay attention to the bundling at each place value that is required.

1. $36 + 21$

2. $23 + 77$

3. $269 + 173$

4. **$4507.89 + 103.54$**

5. $2482 + 55 + 797$

6. $32.9 + 14.7 + 19.8$

7. $7,347 + 100$

8. **First round each number to the hundreds place then add to approximate the sum $1439 + 1263 + 845$.**

9. $(3x^3 + 4x^2 + 9x + 12) + (8x^3 + 11x + 6)$

Video Log 2.1e

Add the following and show all your reasoning where necessary. You can use the facts that $1\text{km} = 1000\text{m}$, $1\text{m} = 100\text{cm}$.

1. $(4x^3 + 6x^2 + 7x + 12) + (5x^6 + 3x^4 + 7x^3 + 10x + 21)$

2. $f(t) = 4 + \sqrt{t}$, $g(t) = 5t + 2$, simplify the expression for $(f + g)(t)$

3. $2\sqrt{6} + \sqrt[5]{3} + 3\sqrt{5} + 7\sqrt{2} + 6\sqrt[5]{3} + 4\sqrt{5}$

4. $(4 + 2i) + (7 + 6i)$

5. $6(3x + 4) + 5x(3x + 4)$

6. $\sqrt{2}(x - 3) + a(x - 3)$

7. $a(u + v) + b(u + v)$

8. $a(a - b) + b(a - b)$

9. $3a(a + b) + 5a(a + b)$

10. $\sqrt{3a}(t + p) + \sqrt{3a}(t + p)$

11. $4\text{km} + 7\text{m} + 100\text{cm}$

Video Log 2.1f

Draw a strip diagram or rectangles to represent the addition process for the following examples. Use the above examples to help you.

1. $\frac{2}{7} + \frac{3}{7}$

2. $\frac{1}{4} + \frac{1}{3}$

3. $\frac{2}{5} + \frac{2}{3}$

4. $4\frac{1}{2} + 1\frac{2}{3}$

5. $\frac{2}{x} + \frac{1}{3}$

Convert to a common denominator and add.

1. $\frac{3}{4} + \frac{4}{x}$

2. $\frac{3}{2} + \frac{3}{4}$

3. $4\frac{2}{3} + 3\frac{1}{2}$

2.2 Multiplication

Lecture

📺 Properties of Multiplication <http://www.youtube.com/watch?v=5tt0WWHEJm4> (10 min, video log 2.2a)

📺 Visualizing Multiplication <http://www.youtube.com/watch?v=0ofeTiqGSFs> (13 min, video log 2.2b)

📺 Adding Rational Expressions Using Multiplication
<http://www.youtube.com/watch?v=xhsxrYVBFu8> (5 min, video log 2.2b)

1. Please include a **summary** and **your detailed notes** from the lectures or e-text reading of this section. Failure to provide a summary and your notes could result in receiving a zero for this section.
2. List all the questions you had while watching the lectures or reading the e-text pages for this section. Do not just say “everything,” but please be specific and elaborate.
3. List all the video log questions on which you were stuck for this section. Do not just say “all,” but please be specific. Make sure you have attempted all the video log questions. You do not have to get them all correct. The attempt is what is important.
4. If using ALEKS, list all the topics on which you would like help.

Video Log 2.2a

1 Answer true or false and justify your answer.

a. Is $3 \times (2 \times 5) = (3 \times 2) \times (3 \times 5)$?

b. Is $3 + (2 + 5) = (3 + 2) \times (3 + 5)$?

c. Is $(a + b)^2 = a^2 + b^2$?

2 Convert each statement into a multiplication of two numbers.

a. $8 + 8 + 8 + 8 + 8 =$

b. **How many paws total are there in a group of 7 dogs?**

c. What is the value in dollars of 7 pounds of strawberries that cost \$2.40 a pound?

d. How many miles does a car travel in three hours if in each hour it travels 65 mi?

3 John bought 4 tires at \$65 each and spent another \$53 on gasoline. Write the total spent as an arithmetic problem and compute this amount.

- 4 Compute the volume of the box and the total surface area of all six faces of the box. Include appropriate units for the area and volume!

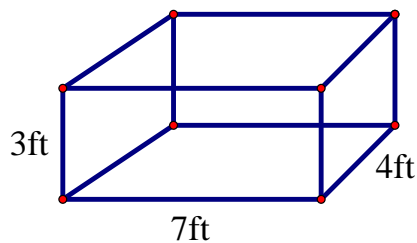

- 5 Identify the property of real numbers that justifies each equation. Select from: Commutative property of addition and of multiplication; Associative property of addition and of multiplication; Additive identity property; Distributive property of multiplication over addition; Multiplicative identity property.

a. $5 \cdot x = x \cdot 5$

b. $50 \left(\frac{1}{2} + 2 \right) = 50 \cdot \frac{1}{2} + 50 \cdot 2$

c. $50 \cdot (4 \cdot 3) = (50 \cdot 4) \cdot 3$

d. $26 \left(5 \cdot \frac{1}{2} \right) = 26 \left(\frac{1}{2} \cdot 5 \right)$

e. $(5 + 0) \cdot x = 5 \cdot x$

Video Log 2.2b

Multiply the following and combine like terms.

1. $3(2x + 4)$

2. $(4 + x)(2x + 3)$

3. $(3x^2 + 2x + 4)(2)$

4. $(a + b)(a + b)$

5. $(2a + 3b)^2$

6. $(a + b)^3$

7. 23^2 (no calculators)

8. 345×53

9. 34.5×0.0053

10. Compute 11% of \$20,000

11. 600×9

12. 400×67

13. Use the distributive property to compute 12×306 by viewing $306 = 300 + 6$ and filling in each box in $12 \times (300 + 6) = (\quad) + (\quad) = (\quad)$

14. Compute the \$ amount of a 35% markdown on a \$80 dollar coat. Do this with multiplication and with a strip diagram.

15. Compute the simple interest earned over 3 years on a principle of \$4000 with interest rate of 3.5%.

16. Compute the product of the number $G = 6.7 \times 10^{-11}$ and $M = 6 \times 10^{24}$. $M \cdot G = ?$ Leave your answer in scientific notation.

17. If $f(x) = 3$, and $g(x) = 2x + 4$, then find $f(x) \cdot g(x)$. This function is referred to as the product function and denoted as $(f \cdot g)(x)$.

Video Log 2.2c

Perform the following additions

1. $\frac{1}{x+1} + \frac{3}{2}$

2. $\frac{1}{a+1} + \frac{a}{a+2}$

3. $\frac{x}{2x+1} + \frac{5x}{x+3}$

For My Eyes Only

4. $\frac{(3x + 2)}{x + 1} + \frac{5x}{x + 4}$

For My Eyes Only

5. $\frac{(x + 3)}{x + 4} + \frac{(5x + 2)}{2x + 1}$

2.3 Subtraction as the inverse operation to addition

Lecture

📺 Properties of Subtraction <http://www.youtube.com/watch?v=W9PEgpFyAYg> (15 min, video log 2.3 a)

📺 Subtraction Algorithm <http://www.youtube.com/watch?v=azaR-4ySSwQ> (9 min, video log 2.3 a)

📺 Visualizing Subtraction http://www.youtube.com/watch?v=PwQGc_1p0jQ (8 min, video log 2.3 b, 2,3 c)

📺 Subtraction <http://www.youtube.com/watch?v=E7Cj8QnEmNo> (12 min, video log 2.3 d)

📺 Subtraction of Rational Expressions <http://www.youtube.com/watch?v=Vuvmrq54b4w> (8 min, video log 2.3 e)

1. Please include a **summary** and **your detailed notes** from the lectures or e-text reading of this section. Failure to provide a summary and your notes could result in receiving a zero for this section.
2. List all the questions you had while watching the lectures or reading the e-text pages for this section. Do not just say “everything,” but please be specific and elaborate.
3. List all the video log questions on which you were stuck for this section. Do not just say “all,” but please be specific. Make sure you have attempted all the video log questions. You do not have to get them all correct. The attempt is what is important.
4. If using ALEKS, list all the topics on which you would like help.

Video Log 2.3a

1. What do you do when there is a zero in the next place value to the left as occurs in the problem $505 - 179$?

2. What happens if there is no digit on the left to borrow from as in $17 - 56$? Explain what to do then.

3. Answer the following questions?

a. Is subtraction commutative? In other words if a and b are any two mathematical objects we have studied so far, is $a - b = b - a$?

b. Explain if $a - b$ is the additive inverse of $b - a$.

c. Explain if $-1(a - b) = b - a$.

Video Log 2.3b

For all problems below show how to visualize the addition or subtraction on a number line.

1. $-4.5 + 2$



2. $-3 - 2$



3. $-1.1 - (-5)$



4. $-5 + 3$



5. $5 - (-3)$



6. $2.3 - 4$



7. $-23 - 35$



8. $-54 + 22$



9. $-11.3 - 8.5 + 4.2$



Video Log 2.3c

Plot the following addition and subtraction problems of complex numbers in the complex plane.

1. $(3 - 4i) + (-5 + 2i)$

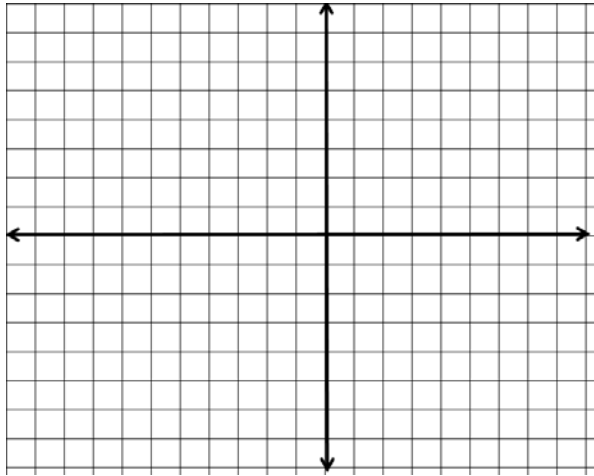

2. $(2 - 4i) - (3 - 2i)$

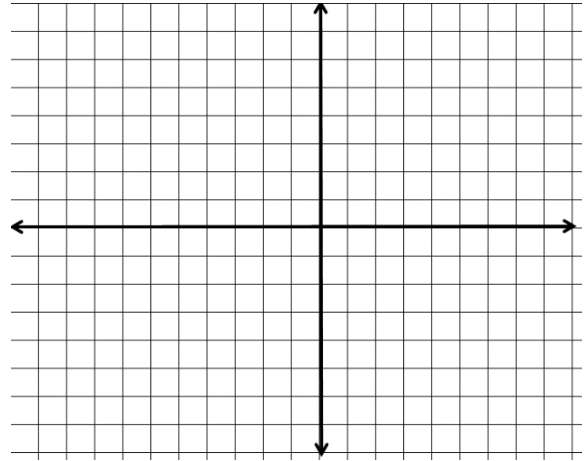

Find the absolute value of

3. $3 - 4i$

4. $2 + 5i$

Video Log 2.3d

Combine like terms where possible and identify the units in each problem

1. $236 - 122$

2. $325 - 179$

3. $312 - 123$

4. **$4507.83 - 103.54$**

5. Adam skied 1245 km in 2013 and 1057 km in 2012. How many more km did he ski in 2013 than in 2012?

6. First round each number to the nearest hundreds place and then subtract to approximate $1378 - 652$

7. **$(4x^3 - 6x^2 - 7x + 12) - (5x^6 + 3x^4 - 7x^3 + 10x - 21)$**

8. $f(t) = 4 - \sqrt{t}$, $g(t) = 5t - 2$, find $(f - g)(t)$

9. $-2\sqrt{6} - \sqrt[5]{3} - 3\sqrt{5} - 7\sqrt{2} + 6\sqrt[5]{3} - 4\sqrt{5}$

10. $(4 - 2i) - (-7 - 6i)$

11. $6(3x - 4) - 5x(3x - 4)$

12. $\sqrt{2}(x - 3) - a(x - 3)$

13. $a(u + v) - b(u + v)$

14. $a(a - b) - b(a - b)$

15. $3a(a + b) - a(a + b)$

16. $\sqrt{3a}(t + p) - \sqrt{3a}(t + p)$

17. $4km + 7m - 100cm$

Video Log 2.3e

Perform the following subtractions.

1. $\frac{1}{x-1} - \frac{3}{2x-1}$

2. $\frac{4}{a-1} - \frac{a}{a-2}$

3. $\frac{x}{2x-1} - \frac{5x}{3-x}$

4. $\frac{(3x-2)}{x-1} - \frac{5x}{x-4}$

5. $\frac{(x+3)}{x-4} - \frac{(2-5x)}{2x-1}$

For My Eyes Only

Answer true or false and justify your answers using correct mathematical terminology.

6. $(-3x^3 - 4x^2) - (5x^3 - 9x^2) = -8x^3 - 13x^2$

7. $x^2(x^3)(x^4) = (x^2x^3)(x^2x^4)$

8. $2(3 \times 5) = (2 \times 3) \times (2 \times 5)$

9. $4 - (3 + 2) = (4 - 3) + (4 - 2)$

10. $(3 + 2) - 4 = (3 - 4) + (2 - 4)$

11. $-2(-4 - 5) = 8 - 10$

2.4 Factoring

Lecture

Prime factors and multiples of expressions

http://www.youtube.com/watch?v=wy7pm8wjm_8 (8 min, video log 2.4a)

Multiples <http://www.youtube.com/watch?v=f3ZdozzChjQ> (9 min, video log 2.4a)

Least Common Multiples <http://www.youtube.com/watch?v=wJCWNcytyXE> (15 min, video log 2.4b)

Adding Rational Expressions Using LCM <http://www.youtube.com/watch?v=O0V6hbTE-2s> (12 min, video log 2.4c)

Factoring Whole Numbers http://www.youtube.com/watch?v=snMzQARfX_M (8 min, video log 2.4d)

Introduction to Factoring Polynomials <http://www.youtube.com/watch?v=JR4rMAd0Mhg> (13 min, video log 2.4e)

Adding and Subtracting Rational Expressions using Basic Factoring
<http://www.youtube.com/watch?v=p8tMoTPFyPI> (5 min, video log 2.4f)

1. Please include a **summary** and **your detailed notes** from the lectures or e-text reading of this section. Failure to provide a summary and your notes could result in receiving a zero for this section.
2. List all the questions you had while watching the lectures or reading the e-text pages for this section. Do not just say “everything,” but please be specific and elaborate.
3. List all the video log questions on which you were stuck for this section. Do not just say “all,” but please be specific. Make sure you have attempted all the video log questions. You do not have to get them all correct. The attempt is what is important.
4. If using ALEKS, list all the topics on which you would like help.

Video Log 2.4a

Answer yes, or no. Explain why or why not.

- Is $11^4 \times 5^5 \times 13^8$ a multiple of :
 - $11^2 \times 5^4 \times 13^3 \times 7^8$
 - $11^3 \times 5^2$

- Is $(x-1)^4 \times (3-5x)^6 \times (x^2+1)^8$ a multiple of :
 - $(x-1)^2$
 - $(x+\sqrt{2})^5(x-1)^4 \times (3-5x)^6(x^2+1)^8$

- Is $11^3 \times 5^2 \times 2^9 \times 3^{24}$ a multiple of :
 - 2×3 ,
 - $2^4 \times 3^5 \times 3^8$
 - $2^2 \times 3^4$
 - 11

- Is $(x-1)^2 \times x^6 \times (3x+1)^8$ a multiple of :
 - $(x-1)^{12} \times x^2 \times (3x-1)^3$
 - x

- Is $(x-\sqrt{3})^5(x-1)^2 \times (3+5x)^6(x+1)^8$ a multiple of :
 - x
 - $x-1$

- Is $2^4 \times (3^2)^5 \times 5^3$ a multiple of :
 - $2^2 \times 3^7$
 - $2^3 \times 3 \times 5^0$

- Is $(x+1)^2 \times x^6 \times (x^2+x+1)^8$ a multiple of :
 - $x(x^2+x+1)^2$
 - $(x+1)^3 \times x^2 \times (x^2+x+1)^4$

Video Log 2.4b

Determine the least common multiple of the numbers or polynomial expressions that appear. Explain your reasoning.

1. 28 and 24
2. 12, 6, and 8
3. $x(x + 1)$, and $(x + 1)(x - 2)$
4. 4, 7, and 15
5. $(2x - 1)(3 - x)$, and $(2x + 1)(3 + x)$
6. $2^4 \times 3^5 \times 3^8$, $2^9 \times 3^{24}$, and $11^3 \times 5^2 \times 2^9 \times 3^{24}$
7. $2^4 \times (3^2)^5 \times 5^3$, $2^2 \times 3^7$, and $2^3 \times 3 \times 5^0$
8. $(x + 1)^2 \times x^6 \times (x^2 + x + 1)^8$, $x(x^2 + x + 1)^2$, and $(x - \sqrt{3})^5 (x - 1)^2 (x + 1)^3 \times x^2 \times (x^2 + x + 1)^4$
9. $x^2(3x + 1)$, and $x(3x + 1)$
10. $(x^2 + 1)(x - 1)$, and $(x + 1)(x - 1)(x^2 + 1)$

11. $(1 + 5x)(x - 7)$, and $(5x + 1)(1 - x)(x - 7)$

12. $(2x + 1)(1 - x)$, and $(1 + x)(2x + 1)$, $(3 - x)(1 - x)$

Answer true or false and justify your answer.

13. The least common multiple of 2, and $(2 + 1)$ is 2.

14. The least common multiple of 2, and $(2 + 1)$ is $2 + 1$.

15. The least common multiple of x and $(x + 1)$ is x .

16. The least common multiple of x and $(x + 1)$ is $x + 1$.

17. The least common multiple of x and $(x + 1)$ is $x(x + 1)$.

18. The least common multiple of $(x^2 + 1)$, and $(x + 1)$, is $x^2 + 1$

Video Log 2.4c

Perform the following operations and simplify your answers.

1. $\frac{2}{15} - \frac{5}{6}$

2. $\frac{3a}{b^2c^3} - \frac{4bk}{a^7b^{12}c}$

3. $\frac{29}{2^{13}3^{22}5^2} - \frac{11}{2^73^{12}5^{12}}$

4. $\frac{2}{a^{13}b^{22}c^2} - \frac{3}{a^7b^{12}d^{12}}$

5. $\frac{3d^3}{b^{10}c^2} - \frac{b^3}{c^7d^6}$

For My Eyes Only

6. $\frac{3a^2}{5b^{10}c^{10}} - \frac{6b^3}{2^2a^{10}c^7}$

For My Eyes Only

7. $-\frac{2a}{b^2cd^3} - \frac{3b^5}{a^2b^{12}d^{12}}$

8. $\frac{(5x+1)}{(x+1)(x-2)} - \frac{(3+x)}{(x-2)(x-1)}$

9.
$$\frac{x}{(x+1)(x-1)} + \frac{(x+5)}{(x-2)(x-1)}$$

For My Eyes Only

10.
$$\frac{(x-2)}{(x-1)(3x-2)} - \frac{(x-1)}{(x-2)(3x-2)}$$

11.
$$\frac{4}{2(x+5)} - \frac{5}{6(x+5)(x-5)}$$

$$12. \quad -\frac{3}{(x-4)(x-1)} + \frac{(3+x)}{(x-1)}$$

For My Eyes Only

$$13. \quad \frac{(1-5x)}{(x+2)(x-2)} - \frac{(2+x)}{(x-2)(x-1)}$$

$$14. \quad \frac{3}{(x+1)^3(x-2)^2} - \frac{5x}{(x-2)^3(x+1)^2}$$

Video Log 2.4d

1. State whether each of the numbers 285, 432, 666, 2430 are divisible by 2, 3, 5, or 9.

Find the greatest common factor of the algebraic expressions given below.

2. 24, 30

3. 324, 360

4. $a^4b^{10}c^3, a^{12}c^4d^2$

5. $(2x - 1)(x + 3), (2x - 1)(x - 3)$

6. $(x + 1)(x - 1), x^2(x + 3)$

7. $2(x + 1)x^3, 6x^4(x + 1)^4$

8. $(2x + 1)(2x - 1)^{10}, (2x - 1)^4(x - 1)^2$

9. $-4p, -18q$

10. $2u(u + v), -6v(u + v)$

11. $-16p^4q, 54pq^4$

Video Log 2.4e

Factor the greatest common factor out in the polynomial expressions below.

1. $-42a^3b^{10} - 30a^5b^{15}$

2. $a^2bc + ab^2c + abc^2$

3. $8x^3 - 12x^2 + 10x$

4. $16x^3y - 18xy^3$

5. $-75x^{23}y^{12} - 30x^{15}y^{25}$

6. $3x(x - y) - 5y(y - x)$

7. $pq - p^2q^2$

8. $xu + yu$

9. $x(u + v) - y(u + v)$

10. $(x + 1)(y + 2) - (x + 2)(y + 2)$

11. $(x + 1)^2(4x - 1) + (x + 1)(4x - 1)^2$

Video Log 2.4f

Perform the following operations. Use the previous two examples as a template on how to write your answers. Show all your work clearly

1. $\frac{1}{12x - 6} + \frac{x}{5x^2 + 10x}$

For My Eyes Only

2. $\frac{(3 + 2x)}{x(x + 1) - 3(x + 1)} - \frac{(2x - 1)}{1(x + 5) + x(x + 5)}$

$$3. \frac{q}{p^2 + pq} - \frac{p}{-pq - q^2}$$

$$4. \frac{2a}{a^2 - 3ax} - \frac{4}{a^2 + 3ax}$$

$$5. \frac{1}{3x^2 + x} + \frac{3x}{5x^2 + 15x}$$

2.5 Factoring Trinomials and a geometric interpretation

 Factoring by Grouping Geometrically as Rectangles

http://www.youtube.com/watch?v=JPWGp83_DUE (6 min, video log 2.5a)

 Factoring by Grouping <http://www.youtube.com/watch?v=yyMzSSw8KLO> (5 min, video log 2.5b)

 Factoring Trinomials using Algebra Tiles <http://www.youtube.com/watch?v=-Xy0zEGlb54> (11 min, video log 2.5c)

 Factoring Trinomials Algebraically <http://www.youtube.com/watch?v=lb9eeHyxwm4> (10 min, video log 2.5d)

 Factoring Trinomials by Grouping <http://www.youtube.com/watch?v=hvuH6eXbXWQ> (14 min, video log 2.5d)

 Factoring Trinomials and Application to Adding and Subtracting Rational Expressions <http://www.youtube.com/watch?v=Ja2ul4TGuH0> (7 min, video log 2.5d)

 Factoring the Difference of Two Perfect Squares

http://www.youtube.com/watch?v=cy_n_YfFQIQ (9 min, video log 2.5e, video log 2.5f)

 Factoring the Sum or Difference of Perfect Cube Terms

http://www.youtube.com/watch?v=2XvIb_JtvQQ (12 min, video log 2.5g)

 Application of Factoring <http://www.youtube.com/watch?v=fm0NEgFloMA> (7 min, video log 2.5h)

1. Please include a **summary** and **your detailed notes** from the lectures or e-text reading of this section. Failure to provide a summary and your notes could result in receiving a zero for this section.
2. List all the questions you had while watching the lectures or reading the e-text pages for this section. Do not just say “everything,” but please be specific and elaborate.
3. List all the video log questions on which you were stuck for this section. Do not just say “all,” but please be specific. Make sure you have attempted all the video log questions. You do not have to get them all correct. The attempt is what is important.
4. If using ALEKS, list all the topics on which you would like help.

Video Log 2.5a

Using the previous example as your guide, draw rectangles showing all stages to show how the left hand side expression factors to become the right hand side. See above examples to help you solve these problems.

Hint: start with the quantity furthest to the left.

1. $2x + 2 + bx + b = 2(x + 1) + b(x + 1) = (2 + b)(x + 1)$

2. $3x + 6 + ux + 2u = 3(x + 2) + u(x + 2) = (3 + u)(x + 2)$

3. $2ax + 3a + 2bx + 3b = a(2x + 3) + b(2x + 3) = (a + b)(2x + 3)$

4. $2x - 2 + bx - b = 2(x - 1) + b(x - 1) = (2 + b)(x - 1)$

Video Log 2.5b

Factor each polynomial by grouping.

1. $au - bv - bu + av$

2. $ax^2 - bx + acx - bc$

3. $st^2 - r^2 - rt + rst$

4. $3ax + ay - 3bx - by + 3cx + cy$

(here you may want to try grouping in groups of two for a total of 3 groups and see what happens, like first two terms as one group, then the 3rd and 4th terms as one group and so on)

For the next few problems don't add like terms right way, use factor by grouping of the first two and last two terms.

5. $7x^2 - 14x + 2x - 4$

6. $-3t^2 + 5t - 6t + 10$

Video Log 2.5c

Use algebra tiles to factor the examples in the video log questions below.

Note: If you get stuck on the problems below, you can listen again to the Video Lectures -

Make sure you draw the rectangle representing your final and show your intermediate steps.

1. $x^2 + 3x + 2$

2. $2x^2 + 8x + 6$

3. $2x^2 + 5x + 3$

Video Log 2.5d

Factor each trinomial or state that it is not factorable over the integers.

1. $x^2 + 5x - 6$

2. $x^2 + 3x - 4$

3. $4x^2 + 8x - 5$

4. $6x^2 - 7x - 5$

5. $2x^2 + 5x - 3$

6. $4x^2y - 5xy^2 - 6y^3$

For My Eyes Only

7. $15a^3b^4 - 14a^2b^5 - ab^6$

8. $12p^2 + 11pq - 14q^2$

9. $54x^3 - 93x^2 + 18x$

10. $25a^6b^3 + 10a^5b^4 - 15a^4b^5$

11. **Extra Credit:** Factor completely $9x^2 - 25$

Perform the following operations and simplify your answers.

12. $\frac{3x}{x^2 + 2x - 3} - \frac{1}{x^2 - 3x + 2}$

For My Eyes Only

13. $\frac{5x}{x^2 - 3x + 2} - \frac{1}{2x^2 - x - 1}$

14. $\frac{x + 1}{2x^2 - x - 1} + \frac{x}{6x^2 + 7x + 2}$

15. $\frac{2x^2 + 3x + 1}{2x^2 - 3x + 1} - \frac{3x^2 - 2x - 1}{2x^2 + x - 1}$

Video Log 2.5e

Let $x = 3a$, $y = 2b$, $u = t + 1$, $v = 2c - 1$, $z = -3$, $s = 4$. Use substitution to rewrite the expressions below in terms of the new variables a , b , t , and c .

1. $(x - y)(x + y)$

2. $(u - 2s)(u + 2s)$

3. $(x - y)(x^2 + xy + y^2)$

4. $(s + x)(s^2 - sx + x^2)$

5. $(a - z)(a + z)$

6. $(x - y)(x + y)(x^2 + y^2)$

Video Log 2.5f

Factor the following completely. First identify both quantities that are being squared.

1. $p^2 - 4q^2$

2. $4q^2 - p^2$

3. $9a^6 - 25b^2$

4. $8a^3 - 18ab^2$

5. $12a^3 - 3a$

6. $16a^4 - 81b^4$

7. $1 - x^4$

(Hint: Use the difference of squares twice here!)

8. $(x + 3)^2 - (x - 2)^2$

9. $48^2 - 8^2$

Video Log 2.5g

Factor the following completely.

1. $p^3 - 8q^3$

2. $4q^3 - 32p^3$

3. $27a^6 - 125b^3$

4. $8a^3 - 27b^3c^3$

5. $p^3 + 8q^3$

6. $4q^3 + 32p^3$

7. $27a^6 + 125b^3$

8. $8a^3 + 27b^3c^3$

9. Is it possible to factor the sum of two perfect squares? Try it for $x^2 + 4$.

We have learned several methods for factoring trinomials and binomials. Try the following problems.

Completely factor the following if possible. If the polynomial does not factor, please indicate so.

10. $x^2 + 8x + 15$

11. $x^2 - x - 2$

12. $2x^2 + 5x - 3$

13. $4x^2 - 4x - 15$

14. $14x^2 + 17x - 6$

15. $15x^2 - 24x - 12$

16. $8x^3y^6 - 1$

17. $1 + a^3$

18. $-4t^2 + 8t - 3$ (Start by factoring out (-1).)

For My Eyes Only

19. $4a^2 - 9b^4$

For My Eyes Only

20. $2p^2 + 7pq + 5q^2$

21. $16x^4 - y^8$

22. $12s^2 + 20s - 25$

23. $54a^3 - 16b^3$

24. $8 - 4t$

25. $1 - t^4$

Video Log 2.5h

Perform the following operations. Hint: You will have to factor the denominators to find the least common denominator.

1. $\frac{3}{1-x} - \frac{4x}{x^2-1}$ (Hint: $(1-x) = -(x-1)$)

For My Eyes Only

2. $\frac{3}{2x} + \frac{2}{x^2-4} - \frac{3}{x^2+2x}$

3. $\frac{1}{x^3 - 8} - \frac{x}{x^2 + 2x + 4}$

For My Eyes Only

4. $\frac{3}{x^2 - 9} - \frac{5x + 2}{x^3 - 27}$

2.6 Multiplication of Rational and Radical Expressions

Lectures

📺 Multiplication of Rational Numbers and Expressions <http://www.youtube.com/watch?v=e-F4CpSXzJ4> (10 min, video log 2.6a)

📺 Multiplying Rational Numbers and Expressions <http://www.youtube.com/watch?v=czoI6D3NNeg> (12 min, video log 2.6b)

📺 Multiplication and Exponents http://www.youtube.com/watch?v=ExausXVXu_E (15 min, video log 2.6c)

📺 Review of radicals and fractional powers and simplifying radicals <http://www.youtube.com/watch?v=Ab-epECGrI4> (9 min)

📺 Simplifying and Multiplying Radicals Continued <http://www.youtube.com/watch?v=xSEpcZdcBHc> (9 min, video log 2.6d)

📺 Rationalizing Denominators of Radical Expressions <http://www.youtube.com/watch?v=BM7KwGKZBbs> (8 min, video log 2.6e)

1. Please include a **summary** and **your detailed notes** from the lectures or e-text reading of this section. Failure to provide a summary and your notes could result in receiving a zero for this section.
2. List all the questions you had while watching the lectures or reading the e-text pages for this section. Do not just say “everything,” but please be specific and elaborate.

3. List all the video log questions on which you were stuck for this section. Do not just say “all,” but please be specific. Make sure you have attempted all the video log questions. You do not have to get them all correct. The attempt is what is important.

4. If using ALEKS, list all the topics on which you would like help.

Video Log 2.6a

Find the value of the following multiplications algebraically, and then show how to interpret your results visually using an appropriate strip diagrams as above.

1. $\frac{4}{5} \times \frac{3}{2}$

2. $\frac{9}{14} \times \frac{2}{3}$

3. $\frac{5}{12} \times \frac{14}{15}$

4. $\frac{3}{2} \times \frac{2}{3}$

5. $6\frac{2}{3} \times 4\frac{1}{4}$

6. John purchased 75 pieces of fruit for a kid's summer camp. Two thirds of the fruit were apples and $\frac{3}{5}$ of these apples were McIntosh variety. How many of the 75 fruit were McIntosh apples.

Video Log 2.6b

Multiply the following rational expressions and write your answers in lowest terms.

1. $\frac{14}{25} \times \frac{15}{21}$

2. $\frac{-4}{9} \times -\frac{27}{6}$

3. $\frac{14}{15} \times \frac{5}{-2}$

4. $\frac{100}{-8} \times \frac{12}{30} \times \frac{-35}{21}$

5. $5\frac{4}{7} \times 2\frac{1}{2}$

6. $3\frac{3}{4} \times 4\frac{2}{3}$

7. $\frac{a^2b^3}{b^6} \times \frac{a^2c^3}{bc^5}$

For My Eyes Only

8. $\frac{x^2 - 9}{x^2 + 3x - 4} \times \frac{x^3 + 64}{3x^2 + 8x - 3}$

9. $\frac{x^2 + 2x + 1}{1 - x^2} \times \frac{5x^2 - 6x + 1}{5x^2 + 4x - 1}$

10. $\frac{x^2 - 9}{x^2 + 2x + 4} \times \frac{x^3 - 8}{x^2 - 5x + 6}$

Answer True or False and give a justification.

11. Is $\frac{x^2 + 2x + 5}{x^2 + 3x - 1} = \frac{x^2 + \cancel{2x} + 5}{x^2 + \cancel{3x} - 1} = \frac{2x + 5}{3x - 1}$?

12. $-\frac{2}{3} = \frac{-2}{-3}$?

13. $\frac{x-1}{1-x} = 1$?

Video Log 2.6c

Simplify the following algebraic expressions and write your answer without any negative exponents. Assume that all variables are nonzero real numbers.

1. $\left(\frac{2}{3}\right)^{-3}$

For My Eyes Only

2. $\left(\frac{3}{4}\right)^{-2} \times \left(\frac{9}{2}\right)^2$

3. $(a^{-3}b^2)^{-3}$

4. $(-3a^3b^{-2}c)^3(b^6c^{-4})^2$

5. $\left(\frac{a^{-4}}{b^2}\right)^{-3}$

$$6. \left(\frac{x^{-7}}{2y^3}\right)^2 \left(-\frac{6x^3}{y^{-3}}\right)^2$$

For My Eyes Only

$$7. \left(\frac{15x^5y^{-3}}{9x^{-4}y^3}\right)^2$$

$$8. \left(\frac{-4x^{-2}y^9}{12x^{-3}y^5}\right)^{-2}$$

$$9. \left(\frac{13345x^{-234}y^{459}}{1002x^{-398}y^{5019}}\right)^0$$

Video log 2.6d

Assume that all the variables are positive real numbers. Simplify the following and write your final answer as one radical term.

1. $a^{\frac{3}{7}}a^{\frac{1}{2}}$

2. $x^{\frac{5}{4}}x^{-\frac{2}{3}}$

3. $x^{\frac{5}{4}}x^{\frac{2}{3}}$

4. $\frac{x^{\frac{5}{4}}}{x^{-\frac{1}{2}}}$

5. $\frac{y^{\frac{1}{2}}y^{\frac{2}{3}}}{y^{\frac{3}{4}}}$

6. $\sqrt[3]{a^5}\sqrt{a^3}$

7. $\frac{\sqrt[3]{a}}{\sqrt[4]{a^5}}$

8. $\sqrt[3]{25}\sqrt{5}$ (Write using a base of 5.)

9. $\sqrt[5]{8^3}\sqrt{4}$

10. $\sqrt[3]{x^7}\sqrt[5]{x^8}$

Simplify the following.

11. $\sqrt{25}$

12. $\sqrt{125x^3}$

13. $3\sqrt{x} \times 2\sqrt{x}$

14. $\sqrt[3]{-8a^3b^7}$

15. $(2 + 4\sqrt{3})(3 + 5\sqrt{2})$

16. $(3 - 2\sqrt{3})(3 + 2\sqrt{3})$

17. $\sqrt{48}$

18. $\sqrt[4]{32a^{15}b^4}$

Video Log 2.6e

Simplify the following radicals and do not leave any radicals in the denominator.

1. $\frac{1}{\sqrt{5}}$

2. $\frac{\sqrt{2x}}{\sqrt{27}}$

3. $\frac{4}{\sqrt[3]{5}}$

4. $\frac{1}{\sqrt[3]{4x^2}}$

5. $\frac{1}{\sqrt[4]{9x}}$

6. $\frac{2 - 3\sqrt{5}}{2 + 3\sqrt{5}}$

7. $\frac{1 + 4\sqrt{3}}{2 - 5\sqrt{2}}$

8. $\frac{2 + 7i}{3 + 2i}$

9. $\sqrt[3]{-8a^7}$

10. $\sqrt[3]{5x^3y^{10}} \sqrt[3]{25x^2y^2}$

11. $\sqrt{3} \sqrt[3]{9}$ Note that one of these is a square root and the other a cube root! Switch to exponent notation first and then convert back to a radical.

12. $\sqrt[3]{x^2} \sqrt[5]{x^4}$

13. $-\sqrt[4]{16xy^6}$

14. $\sqrt{12x^5y^3} \sqrt{6x^3y^5}$

15. $\frac{\sqrt[3]{54x^{-3}y}}{\sqrt{6x^{-1}y^7}}$

16. $3\sqrt{8y^5} - 5x^3\sqrt{16x} + 6y^2\sqrt{2y} - 9\sqrt[3]{2x^4}$

Video Log 2.7a

1. Answer true or false and justify your answer.

a. $4 \div \frac{1}{2} = \frac{4}{1} \div \frac{1}{2} = \frac{4 \times 2}{1 \times 2} \div \frac{1}{2} = \frac{8}{2} \div \frac{1}{2} = \frac{8 \div 1}{2 \div 2} = 8$

b. $\frac{a}{b} \div \frac{c}{d} = \frac{a \div c}{b \div d}$

c. $14 \div 0 = 0$ (How many times can you subtract zero from 14?)

d. $0 \div 14 = 0$ (How many times can you subtract 14 from 0?)

2. State the reciprocal of each number below.

a. $\frac{2}{5}$

b. 17

c. $\frac{1}{3}$

d. π

3. Express each situation as a division problem and evaluate the answer.

a. Hans has picked 85 cobs of sweet corn and will sell it in bags of 6 cobs each. How many bags will Hans need and how many cobs will remain?

b. John has \$8.75. How many 45 cent peppers can he buy?

c. A class of 25 students purchased a block of lottery tickets and won \$2.5 million dollars. If shared evenly, how many dollars would each student get?

4. Simplify the division problems. Convert improper fractions to mixed numbers.

a. $\frac{3}{4} \div \frac{2}{3}$

b. $\frac{5}{2} \div \frac{25}{8}$

c. $3\frac{2}{3} \div 1\frac{1}{4}$

Video Log 2.7b

Divide the following rational expressions and write your answer in lowest terms.

1. $\frac{1960}{35}$

2. $\frac{12.6}{0.02}$

3. $2\sqrt{24} \div \sqrt{32}$ Write this as a fraction and then simplify the radicals.

4. $720 \div 9$

5. $240,000 \div 60$

6. Round each number to its highest place value and estimate $7563 \div 781$.

For My Eyes Only

7.
$$\frac{x^2 - 9}{x^2 + 3x - 4} \div \frac{3x^2 + 8x - 3}{x^3 + 64}$$

8.
$$\frac{x^2 + 2x + 1}{1 - x^2} \div \frac{5x^2 + 4x - 1}{5x^2 - 6x + 1}$$

9.
$$\frac{x^2 - 9}{x^2 + 2x + 4} \div \frac{x^2 - 5x + 6}{x^3 - 8}$$

Video Log 2.7c

Use the division algorithms to perform the following divisions. Write your final answer in the form $\text{Quotient} + \frac{\text{Remainder}}{\text{Divisor}}$.

1. $411 \div 24$

2. $9870 \div 13$

3. $0.000987 \div 0.2$ Report as a decimal number

4. $(-9x^5 + 12x^4 - 4x^3 - 3x^2 + 5x + 2) \div (-3x + 2)$

5. $(5x^3 + 22x^2 - 4) \div (x - 1)$ (Remember to put in $0x$ in the dividend!)

Compute the decimal representation of the fractions below

6. $\frac{17}{13}$. (Hint: The repeating pattern has 6 digits repeat.)

7. $34.9 \div 2.5$

8. $(9.3 \times 10^7) \div (3 \times 10^4)$ and leave your answer in scientific notation.

9. Compute $(2.5 \times 10^{-23}) \div (5 \times 10^{-12})$ and leave your answer in scientific notation.

Video Log 2.8a

Simplify the following

1. $3 + 2 \times 7 - 9$

2. $100 \div 2 \times 5 - 7^2 + 9$

3. $11 - 3 \times 6 + 8$

4. $21 - 6 \times 2 - 3$

5. $(21 - 6) \times 2 - 3$

6. $(5^2 - 10)^2 + 7$

7. $\sqrt{5^2 - 3^2}$

8. $\frac{\frac{2}{5} + 1}{3^2 - 4}$

$$9. \frac{\frac{1}{2} - \frac{1}{7}}{\frac{3}{7} - \frac{1}{2}}$$

$$10. \frac{-7 + |3^2 - 5|}{(4 - 3)^2 - 3}$$

$$11. 2|13 - 5| - 17$$

$$12. |3 \times 2^2 - 7 \times 5| - 8 \times 3^2$$

$$13. \frac{-7 + (3 \times 2 - 4)^2}{3^2 - 4 + 2 \times 5}$$

$$14. \frac{-5^2 - (3 - 2^2)^3}{3^2 - 5 + 5 \times 2}$$

$$15. \frac{2 + 3 \times 5 \div 2}{2 \times 3 - 10 \div 2}$$

Video Log 2.8b

Simplify the following complex fractions

1.

$$\frac{\frac{3}{4} - \frac{1}{5}}{\frac{1}{2} + \frac{1}{5}}$$

2.

$$\frac{\frac{2}{3} - \frac{3}{4}}{\frac{3}{5} - 1}$$

3.

$$\frac{\frac{1}{a} - \frac{1}{b}}{\frac{1}{a} + \frac{1}{b}}$$

4.

$$\frac{\frac{3x}{x+2} - 2}{3}$$

$$5. \frac{\frac{1}{x} - \frac{1}{x+1}}{\frac{1}{x-1} - \frac{1}{x}}$$

$$6. \frac{\frac{1}{1} - \frac{1}{3+x}}{\frac{1}{x+2} - \frac{1}{2}}$$

Extra Credit

7. Simplify:

$$\frac{1 - \frac{1}{1 - \frac{1}{x}}}{1 + \frac{1}{1 + \frac{1}{x}}}$$

8. Find what is a
- a. Continued fraction
 - b. Golden Ratio

3.1 A Brief History of Equations and Inequalities

Lecture











Introduction to Equations and Inequalities <http://www.youtube.com/watch?v=vZ2mjSUvneQ> (11 min, video Log 3.1a)

Interval Notation <http://www.youtube.com/watch?v=P1llz3XtJLs> (14 min, video Log 3.1a)

1. Please include a **summary** and **your detailed notes** from the lectures or e-text reading of this section. Failure to provide a summary and your notes could result in receiving a zero for this section.
2. List all the questions you had while watching the lectures or reading the e-text pages for this section. Do not just say “everything,” but please be specific and elaborate.
3. List all the video log questions on which you were stuck for this section. Do not just say “all,” but please be specific. Make sure you have attempted all the video log questions. You do not have to get them all correct. The attempt is what is important.
4. If using ALEKS, list all the topics on which you would like help.

Video Log 3.1a

Represent the solutions to the following algebraic inequalities on the number line, and then also write the corresponding interval notation. Use the format shown in the practice problems.

	Algebraic	Graphical Solution on a number line	Interval Notation
1.	$x < 5$		
2.	$x > -3$		
3.	$-4 < x < 2$		
4.	$7 \leq x \leq 10$		
5.	$7 < x \leq 10$		
6.	$x \leq 5, \text{ and } x \geq -2$		
7.	$x < -3 \text{ and } x > 3$		
8.	$\frac{1}{3} < x \text{ or } \frac{4}{5} \geq x$		
9.	$x \leq -\frac{1}{2} \text{ or } x > 5$		
10.	$-\frac{1}{3} \leq x < 5$		
11.	$-\frac{1}{3} < x \text{ or } -\frac{4}{5} \geq x$		

3.2 Solving Equations and Inequalities Using the Additive and Multiplicative properties of equality and inequality

Lecture

- ▣ Additive Property of Equalities and Inequalities <http://www.youtube.com/watch?v=Emlxj6Xj4w0> (10 min, video Log 3.2a)
- ▣ Multiplicative Property of Equalities and Inequalities <http://www.youtube.com/watch?v=IUaQxG8Vn-8> (8 min, video Log 3.2a)
- ▣ Solving Equations and Inequalities <http://www.youtube.com/watch?v=9Ky4kZA1unE> (12 min, video Log 3.2a)
- ▣ Solving Equations and Inequalities <http://www.youtube.com/watch?v=kRbOrSNxKy0> (8 min, video Log 3.2a)
- ▣ Solving Equations <http://www.youtube.com/watch?v=6oGn22clCwA> (11 min, video Log 3.2a)
- ▣ Percentage, Ratio and Proportions Problems <http://www.youtube.com/watch?v=oLoRCRXTYv4> (11 min, video Log 3.2b)
- ▣ Direct and Inverse Variation <http://www.youtube.com/watch?v=sezsOC5fggo> (5 min, video Log 3.2b)

1. Please include a **summary** and **your detailed notes** from the lectures or e-text reading of this section. Failure to provide a summary and your notes could result in receiving a zero for this section.
2. List all the questions you had while watching the lectures or reading the e-text pages for this section. Do not just say “everything,” but please be specific and elaborate.

3. List all the video log questions on which you were stuck for this section. Do not just say “all,” but please be specific. Make sure you have attempted all the video log questions. You do not have to get them all correct. The attempt is what is important.

4. If using ALEKS, list all the topics on which you would like help.

Video Log 3.2a

Solve the following equations for the respective variables. If an equation is an identity, or has no solution, or has an extraneous solution, please state so.

1. $3x - 5 = 2x + 6$

2. $2(x + 1) - 4x = 3(x - 1) - 5x$

3. $5(1 - x) = 3 - 2(3x - 7)$

4. $5 + 2x = x - 9$

For My Eyes Only

5. $11 + 2t = t - 3$

6. $7x - 5 = 2x + 6$

7. $3x + 4.5 = -8.5$

8. $2.3x - 5.6 = 7.4 - 4.2x$

9. $5(1 - x) = 3 - 4(3x - 7)$

10. $5(1 - x) = 1 - x - 4(x - 1)$

11. $5 + \frac{2}{3}x = \frac{3}{2}x - 9$

12. $11 + 2t = 7t - 8$

13. $|x| = \frac{5}{2}$

14. $|2x - 1| = \frac{5}{2}$

15. $|2x - 1| - 3 = \frac{5}{2}$

16. $\frac{5}{x+1} - \frac{2}{3} = 7$

17. $3(x+1) - 2 = \frac{4}{3}(2x-1)$

18. $\frac{3}{x+2} - \frac{1}{3x^2+5x-2} = -\frac{2}{3x-1}$

19. $\frac{2x-4}{x^2-1} = \frac{2}{x+1} - \frac{1}{x-1}$

20. $(x + 1)^3 = -8$

For My Eyes Only

21. $x^2 = 9$

22. $(2x + 3)^2 = 9$

23. $(5x - 1)^2 - 2 = 7$

Solve the following inequalities. Graph each solution on a number line and also write it in interval notation.

24. $3x - 5 < 2x + 6$

For My Eyes Only

Graphical Solution:



Interval Notation:

25. $5(1 - x) \geq 3 - 2(3x - 7)$

Graphical Solution:



Interval Notation:

26. $7x - 5 < 2x + 6$

Graphical Solution:



Interval Notation:

27. $11 + 2t \leq 7t - 8$

Graphical Solution:



Interval Notation:

28. $|2x - 1| + 3 \geq 7$

For My Eyes Only

Graphical Solution: 

Interval Notation:

29. $\frac{2}{x - 1} < 5$

Graphical Solution: 

Interval Notation:

Solve the equations below for the designated variables.

30. Solve for y , $Ax + By = C$

31. Solve for q , $\frac{p}{q} = rt$

32. Solve for F , $T = \frac{5}{9}(F - 32)$

33. Solve for T , $D = RT$

34. Solve for x , $y = mx + b$

35. Solve for f , $\frac{1}{p} = \frac{1}{f} + \frac{1}{q}$

Video Log 3.2b

1. Adam's salary is \$55,000 a year and he earns 65% as much as his friend John. What is John's salary rounded to the nearest dollar?
2. Clare purchased a car for \$23,400 that was on sale for 18% off. What was the presale price of the car?
3. The pie chart below shows the ethnic composition of entering students at the University of Michigan in 2005. If the total of the Hispanic and Asian students was 2457 students, determine the total number of incoming students at the University of Michigan in 2005. Round your answer to the nearest student.

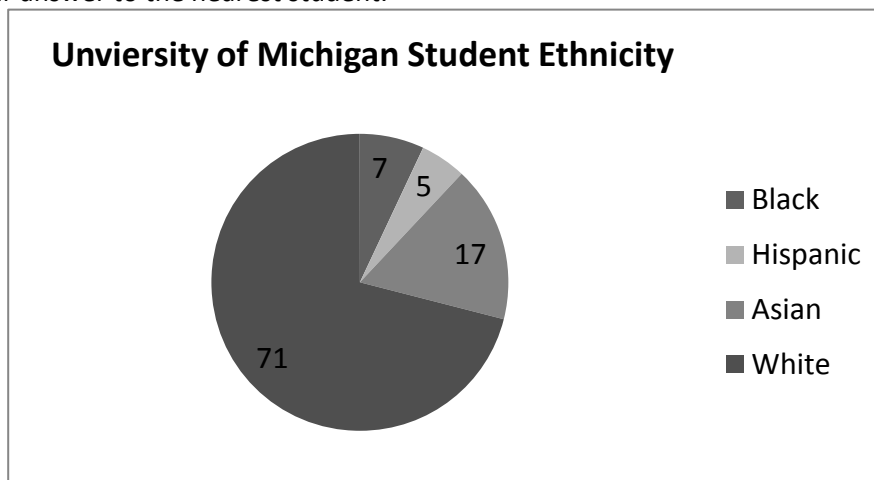

4. Joe can make 25 pizzas in a three hour shift. At this rate, how long would it take him to make 60 pizzas?

5. The polygons below are similar. Determine the length of the dashed side in the right polygon.

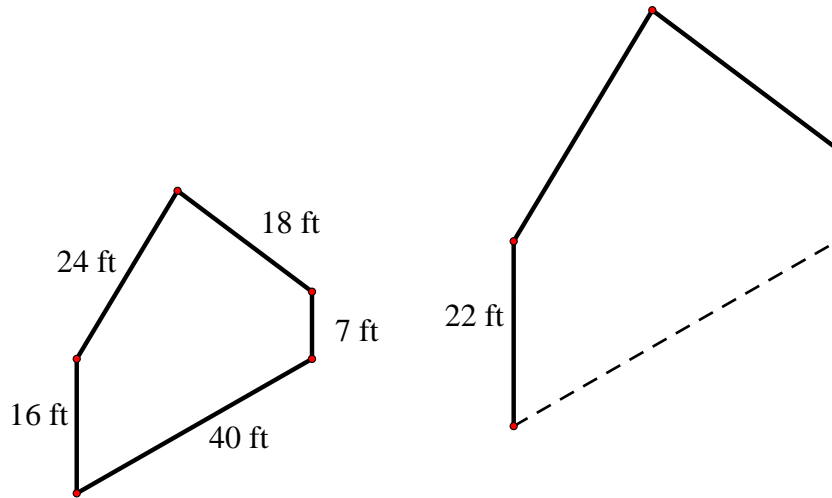

6. A recipe calls for $1\frac{1}{2}$ cups of flour, $\frac{3}{4}$ c sugar and 1 stick of butter. It is critical that these ratios be adhered to in order for the cookies to turn out well. Paul was careless as he started and put in 2 cups of flour instead of the $1\frac{1}{2}$ c and had added the $\frac{3}{4}$ c. sugar before realizing his error. Determine how much total sugar and how much total butter he should use to keep the ratios in line with the recipe.

7. **The weight W of a Lake Michigan brown trout varies directly with the cube of its length l . A 25 inch fish weighs two pounds. Write an equation with a constant of variation k that expresses this variation and use the given data to determine the value of k . Also predict the weight of a 38 inch brown trout.**

Answer: Weight of 38 inch fish is about 7 pounds.

8. The energy intensity of sunlight I varies inversely with the square of the distance d from the sun. On earth which is $1.5 \cdot 10^{11}$ meters from the sun, the light intensity is $1300 \frac{w}{m^2}$. This means that on a piece of ground one meter by one meter, the solar energy comes in at about the same rate as what a hair dryer gives off. Write an equation that expresses this inverse relation between I and d . Also estimate to the nearest tens, the solar energy intensity at Mars which is $2.3 \cdot 10^{11}m$ from the sun.

9. Write an equation that expresses the fact that P varies directly with T and inversely with V . Leave your constant of variation as k . Also determine the value of k if when $T = 300$ and $V = 25$ then $P = 15$.

Video Log 3.3a

Solve the equations below:

1. $x^2 - 7x + 12 = 0$

2. $x^2 + 3x = 10$

3. $2x^2 + x - 6 = 0$

4. $(3x + 1)(x - 2) = x^2 - 4x + 4$

**For My Eyes
Only**

5. $x^3 - 9x^2 + 20x = 0$

6. $\frac{5}{x^2 - 7x + 6} = 3 + \frac{1}{x - 6}$

7. $-\frac{3t}{t - 2} = \frac{12}{t^2 - 6t + 8}$

Solve the inequalities below:

For My Eyes Only

8. $x^2 - 7x \leq -12$

9. $x^2 - 3x - 3 < 1$

10. $\frac{4}{x+2} + 1 \leq \frac{2}{x-1}$

Video Log 3.4a

Solve the following equations and check your solutions. If there are any extraneous solutions, please state so.

1. $\sqrt[4]{1-x} = 2$

For My Eyes Only

2. $\sqrt[3]{2+3x} = -1$

3. $\sqrt{3-x} = \sqrt{1+11x}$

4. $\sqrt{2+x} = \sqrt{3-x} + 1$

5. $\sqrt[5]{2x+1} = 2$

6. $\sqrt{t-2} = t-8$

7. $\sqrt{3t-2} = t-2$

8. $\sqrt{6-t} = \sqrt{2t+5}$

9. $\sqrt{x} - 4 = 5$

10. $x^3 = 15$

11. $(2x - 7)^2 = 25$

12. $(1 - x)^3 = 8$

13. $(11 + 3x)^2 = 5$

14. $(4 + 11x)^5 = 2$

3.5 Quadratic Equations

Lectures

 Quadratic Equations https://www.youtube.com/watch?v=29_SBzxChMw (15 min, video Log 3.5a)

1. Please include a **summary** and **your detailed notes** from the lectures or e-text reading of this section. Failure to provide a summary and your notes could result in receiving a zero for this section.
2. List all the questions you had while watching the lectures or reading the e-text pages for this section. Do not just say “everything,” but please be specific and elaborate.

3. List all the video log questions on which you were stuck for this section. Do not just say “all,” but please be specific. Make sure you have attempted all the video log questions. You do not have to get them all correct. The attempt is what is important.

4. If using ALEKS, list all the topics on which you would like help.

Video Log 3.5a

Complete the following squares and rewrite the quadratic in the form $(x + a)^2$ or $(x - a)^2$.

1. $x^2 + 8x$

2. $x^2 - 12x$

3. $x^2 + 18x$

4. $x^2 - 2x$

Find all the solutions to the following quadratic equations.

5. $3x^2 - 2x + 4 = 0$

6. $5x^2 - 6x - 7 = 0$

For My Eyes Only

7. $x^2 - 4x + 3 = 0$

8. $5x^2 - x + 4 = 0$

9. $5x^2 - 2x + 7 = 0$

10. $x^2 - x - 1 = 0$

11. $9x^2 - 90x = -25$

For My Eyes Only

12. $2x(x - 4) + 3(x + 1) = 5(2x - 7) + 10$

Solve the following equations. If there are any extraneous solutions, please state so.

13.
$$\frac{2x^2 + 2x - 10}{x^2 - 9} - \frac{x - 2}{x - 3} = \frac{-2}{x + 3}$$

For My Eyes Only

14.
$$\frac{2x^2 - 5}{x^2 - 4} + \frac{6}{x + 2} = \frac{4x - 7}{x - 2}$$

15. $\sqrt{2x^2 - 3x} = 3$

16. $\frac{3x + 1}{2x - 2} = \frac{x - 1}{x - 3}$

17. $\sqrt{x - 4} = x - 10$

4.1 Coordinate Plane Geometry

Lecture

📺 Cartesian Coordinate System <http://www.youtube.com/watch?v=QdgdISLovuM> (11 min, video Log 4.1a)

📺 Midpoint Formula http://www.youtube.com/watch?v=kRivyxLD_IM (3 min, video Log 4.1b)

📺 Pythagorean Theorem and Distance Formula <http://www.youtube.com/watch?v=KrLZuOhus4U> (10min, video Log 4.1b)

1. Please include a **summary** and **your detailed notes** from the lectures or e-text reading of this section. Failure to provide a summary and your notes could result in receiving a zero for this section.
2. List all the questions you had while watching the lectures or reading the e-text pages for this section. Do not just say “everything,” but please be specific and elaborate.

3. List all the video log questions on which you were stuck for this section. Do not just say “all,” but please be specific. Make sure you have attempted all the video log questions. You do not have to get them all correct. The attempt is what is important.

4. If using ALEKS, list all the topics on which you would like help.

Video Log 4.1a

1. Write the coordinates of each of the following points plotted below.

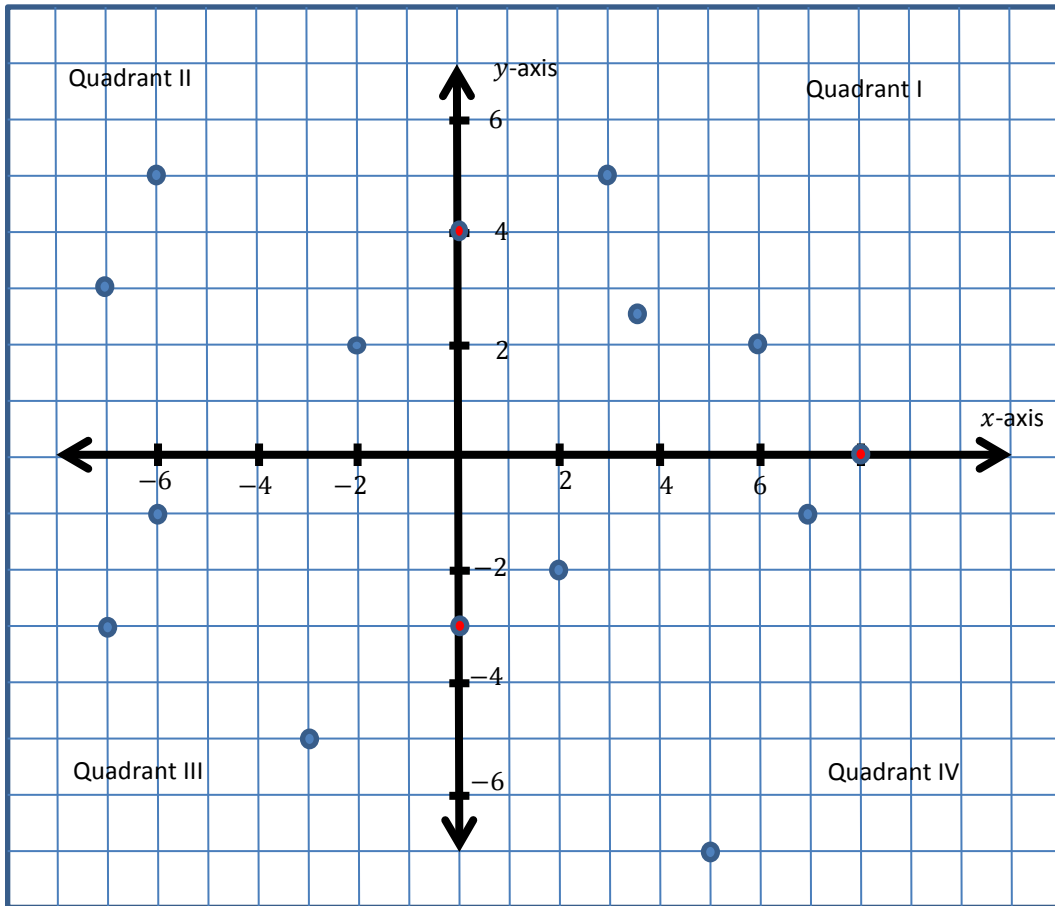

2. Plot each of the following groups of points on a separate rectangular coordinate system. Choose an appropriate scale on your axes for each group.

Group 1 $(-2,1), (3,-1), (3,1), (2,-1), (-7,-7), (-5,-7), (-8,-1), (-7,3)$

Group 2 $(-0.5,0.1), (0.3,-0.1), (0.3,1), (0.2,-0.1), (-0.7,-1.7), (-0.5,-1.7), (-0.8,-0.1),$

Group 3 $\left(\frac{2}{3}, \frac{1}{4}\right), \left(-\frac{2}{3}, -\frac{3}{4}\right), \left(0, \frac{4}{3}\right), \left(-\frac{5}{3}, \frac{1}{4}\right), \left(\frac{5}{3}, -\frac{1}{3}\right)$

Group 4 $(-20,400), (300,-100), (500,100), (200,-150), (-700,-700),$

Group 5 $(20000,400), (30000,100), (50000,100), (20000,150), (70000,700)$

Group 1

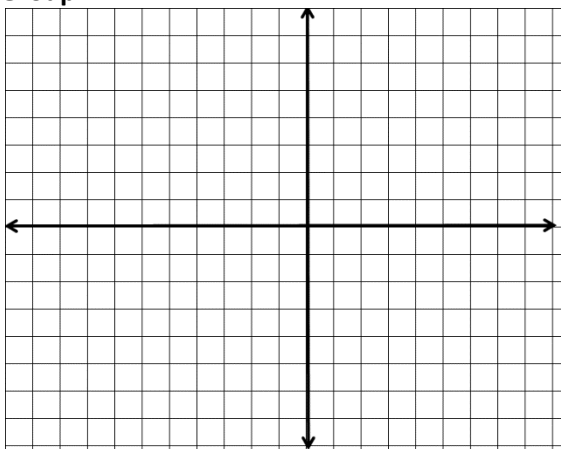

Group 2

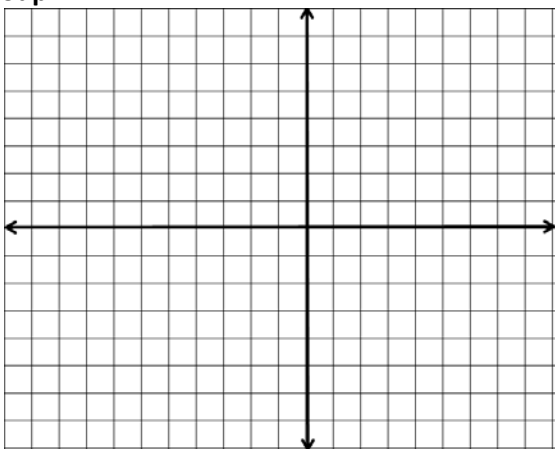

Group 3

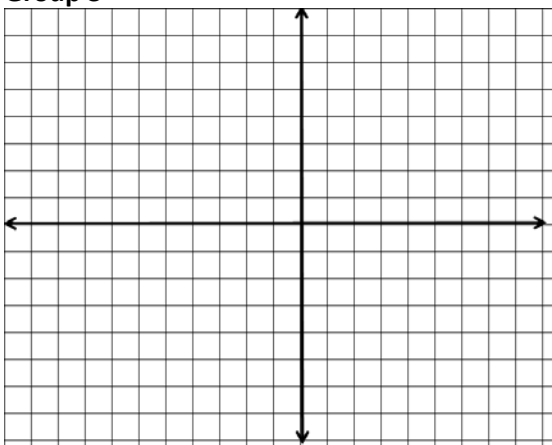

Group 4

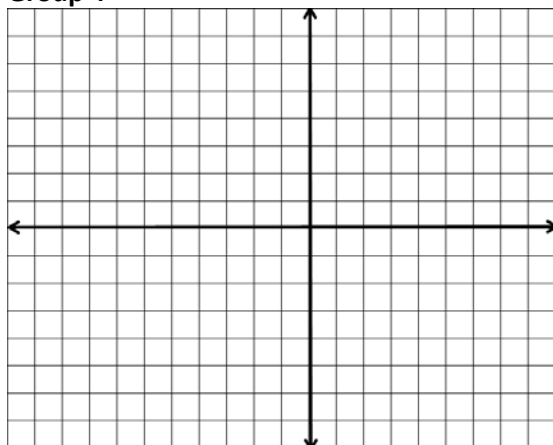

Group 5

(20000,400), (30000,100), (50000,100), (20000,150), (70000,700)

Group 5

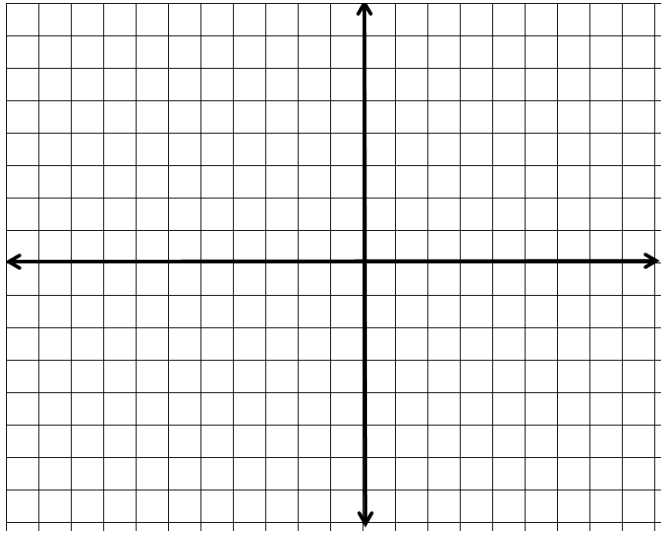

Video Log 4.1b

Find the distance between and the midpoint of the points below.

1. $(-3.5, 2)$ and $(-6, -20)$

Distance:

Midpoint:

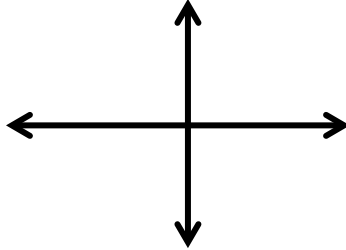

2. $(0, -18)$ and $(-12, 0)$

Distance:

Midpoint:

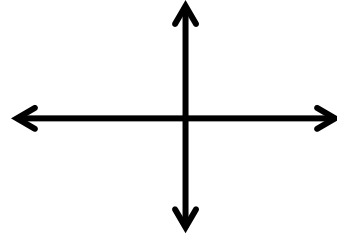

3. $(4, -7)$ and $(-4, -2)$

Distance:

Midpoint:

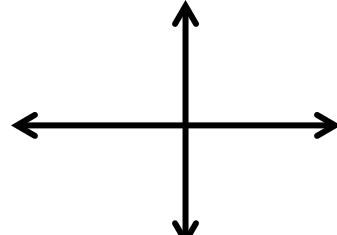

4. $(-5, -13)$ and $(-5, 13)$

Distance:

Midpoint:

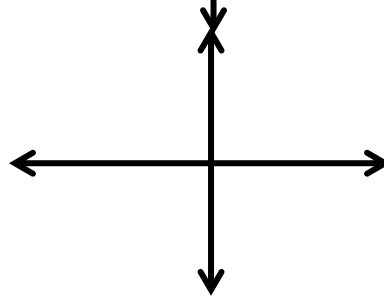

5. $(\frac{5}{2}, \frac{2}{5})$ and $(-\frac{6}{5}, -\frac{11}{2})$

Distance:

Midpoint:

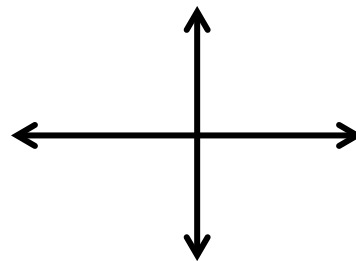

4.2 Graphing solutions to equations in two variables on an x, y -plane

Lecture

Plotting solutions to equations in x and y <http://www.youtube.com/watch?v=MEs1zAr--bc> (11 min, video Log 4.2a)

Graphing Equations and Inequalities in Two Variables <http://www.youtube.com/watch?v=lHCGIPoewJc> (9 min, , video Log 4.2a)

Equations of Circles <http://www.youtube.com/watch?v=fzNXmoCHRck> (10 mins, video Log 4.2a)

1. Please include a **summary** and **your detailed notes** from the lectures or e-text reading of this section. Failure to provide a summary and your notes could result in receiving a zero for this section.
2. List all the questions you had while watching the lectures or reading the e-text pages for this section. Do not just say “everything,” but please be specific and elaborate.
3. List all the video log questions on which you were stuck for this section. Do not just say “all,” but please be specific. Make sure you have attempted all the video log questions. You do not have to get them all correct. The attempt is what is important.
4. If using ALEKS, list all the topics on which you would like help.

Video log 4.2a

1. **Determine if the points $(2, 2)$, $(0, -2)$, and $(2, 4)$ are solution points to each of the equations or inequalities below.**
 - A. $y = 3x - 2$
 - B. $y = 4x^2 - 2$
 - C. $y \leq 4 - x$

2. **Find the missing coordinates so that the point becomes a solution to the given equation or inequality.**
 - A. $(2, y)$ is a solution to $3x - 1 = y$
 - B. $(x, -1)$ is a solution to $2x - 5 \leq y$
 - C. $(0, y)$ is a solution to $4 - 2x = y$

3. Sketch the graphs of the equations below by plotting points (the (x, y) coordinates) using the x -values of $-2, -1, 0, 1, 2$.
- A. $y = -2x + 3$
 B. $y = x^2 - 3$

x	$y = -2x + 3$
-2	
-1	
0	
1	
2	

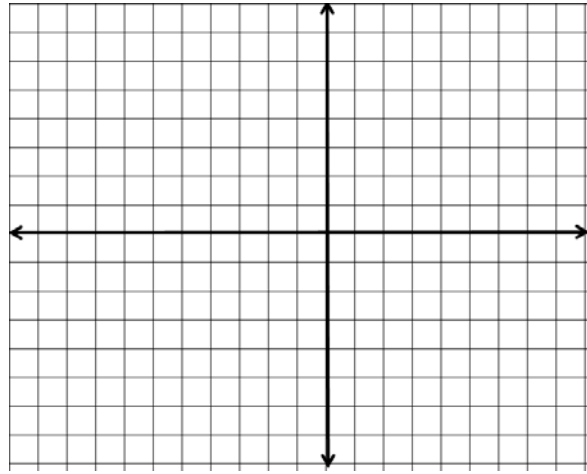

x	$y = x^2 - 3$
-2	
-1	
0	
1	
2	

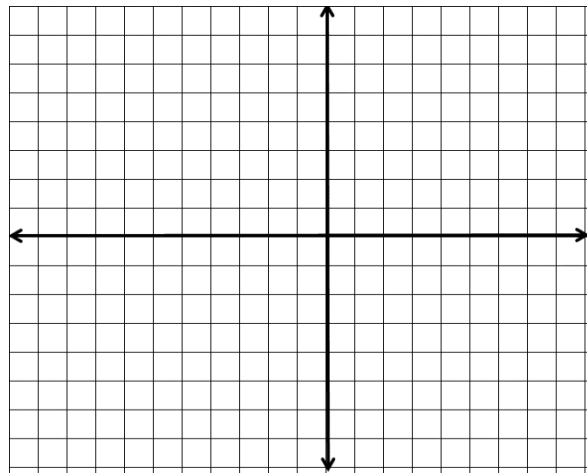

4. Sketch the graphs of the inequalities below. Hint: First plot the relevant equations using information from problem number 3, and then use appropriate test points to graph the solutions to the inequalities.

A. $y \leq -2x + 3$

B. $y > x^2 - 3$

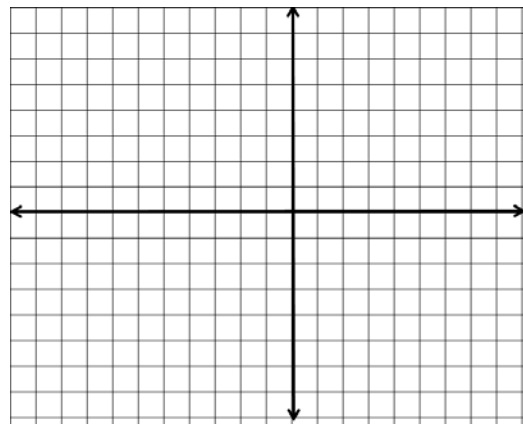
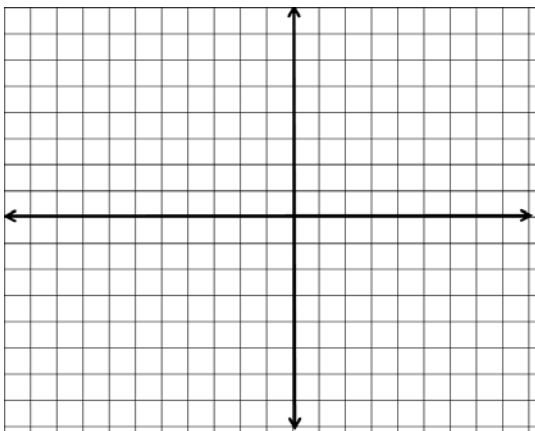

5. Plot the graphs of the circles described by the equations below.

A. $x^2 + y^2 = 36$

B. $(x - 3)^2 + (y - 4)^2 = 25$

C. $(x + 2)^2 + (y - 1)^2 = 9$

A. $x^2 + y^2 = 36$

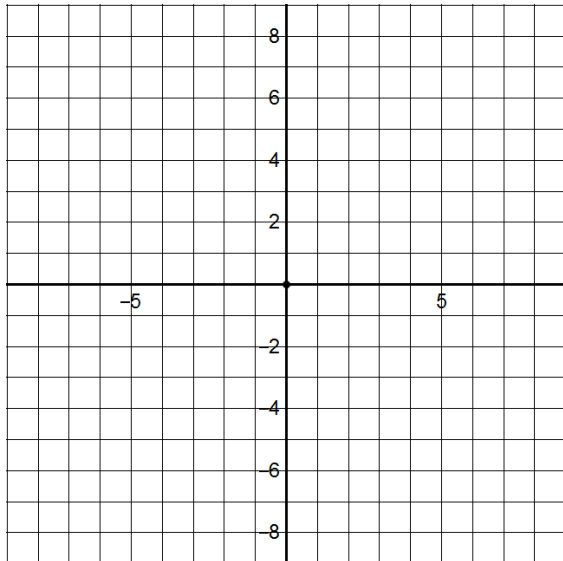

B. $(x - 3)^2 + (y - 4)^2 = 25$

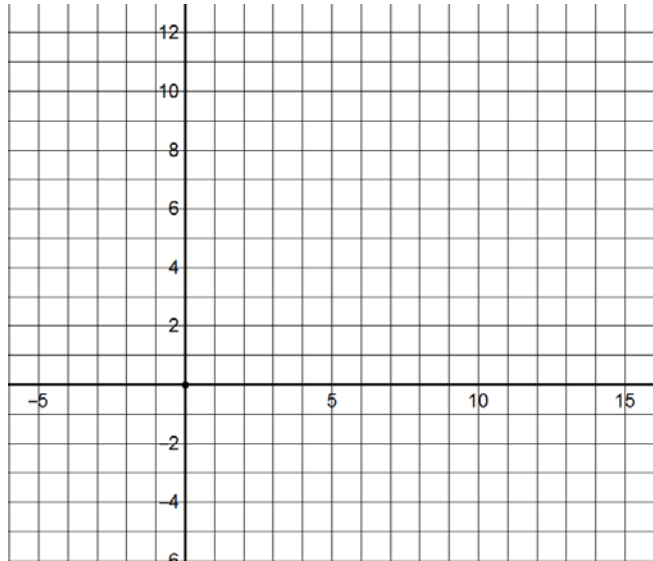

C. $(x + 2)^2 + (y - 1)^2 = 9$

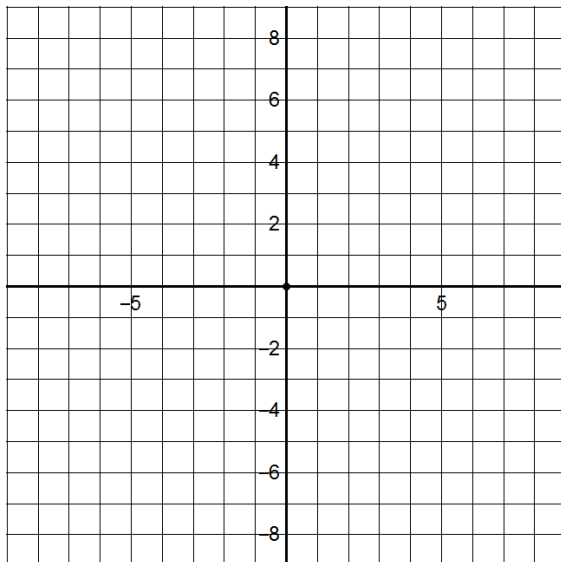

6. Sketch graphs and write equations that represent each circle described below.

A. The center is at $(2, 7)$ and the radius is $r = 9$.

B. Two endpoints of a diameter are the points $(1, 2)$ and $(5, 2)$.

A. The center is at $(2, 7)$ and the radius is $r = 9$.

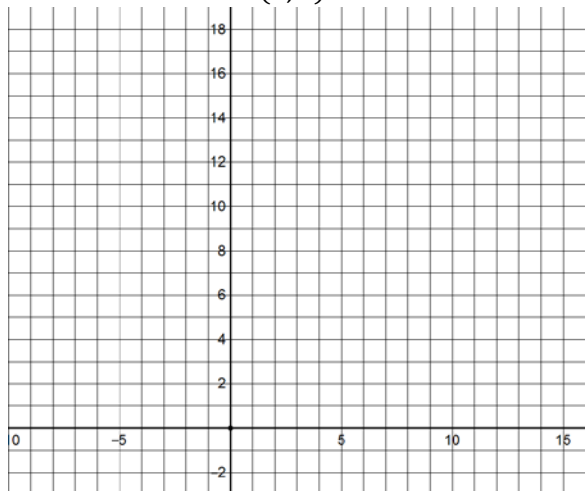

B. Two endpoints of a diameter are the points $(1, 2)$ and $(5, 2)$.

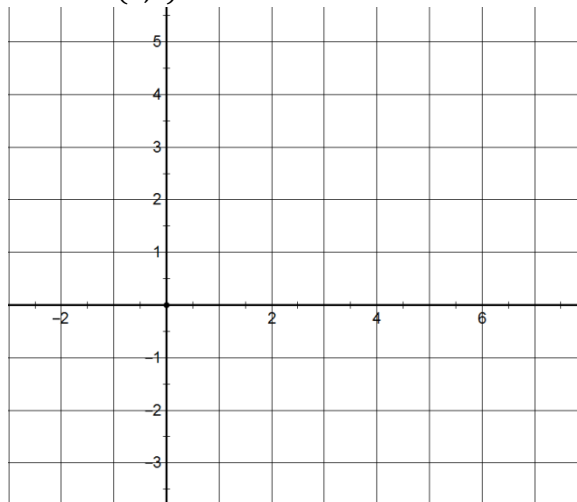

7. Write the equation in standard form for the graph of the circle shown below.

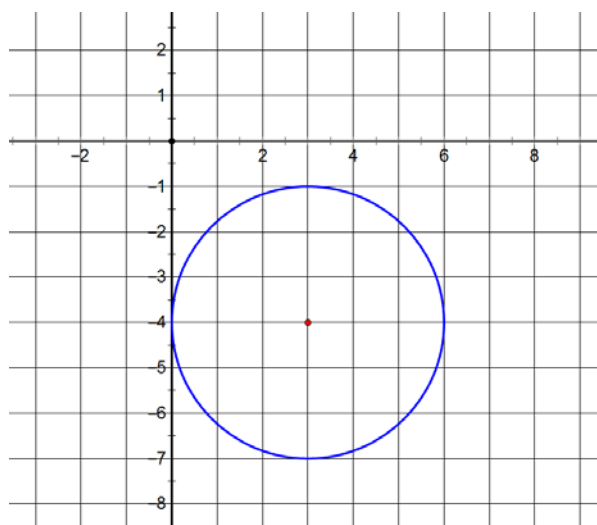

Center of the circle : _____

Radius of the circle: _____

Equation of the circle in standard form:

8. Use Wolfram Alpha to determine which holiday, early in the year, the graph of the equation $(x^2 + y^2 + y)^2 = x^2 + y^2$ is associated with.

4.3 Graphs of linear equations in two variables

Lecture

Horizontal and Vertical lines and their equations http://www.youtube.com/watch?v=lamhB_5youg (6 min, , video Log 4.3a)

Slopes of lines

<http://www.youtube.com/watch?v=hbrLS3ifskQ> (13 min, , video Log 4.3b)

Lines

<http://www.youtube.com/watch?v=l2TPmlzfkLo> (6 min, , video Log 4.3c)

Slope-intercept and point-slope forms of equations of lines

<http://www.youtube.com/watch?v=Mqh-1mGnuU0> (15 min, , video Log 4.3d)

Summary of Lines and Linear Equations and Inequalities in Two Variables

<http://www.youtube.com/watch?v=wq8NG65DZtE> (2 min, , video Log 4.3d)

Solving Systems of Equations and Inequalities http://www.youtube.com/watch?v=Ek8oBqJ2E_4 (14 min, video Log 4.3e)

1. Please include a **summary** and **your detailed notes** from the lectures or e-text reading of this section. Failure to provide a summary and your notes could result in receiving a zero for this section.
2. List all the questions you had while watching the lectures or reading the e-text pages for this section. Do not just say “everything,” but please be specific and elaborate.
3. List all the video log questions on which you were stuck for this section. Do not just say “all,” but please be specific. Make sure you have attempted all the video log questions. You do not have to get them all correct. The attempt is what is important.
4. If using ALEKS, list all the topics on which you would like help.

Video Log 4.3a

1. Find equations of the lines below.

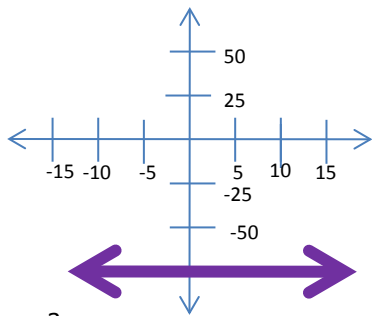

a.

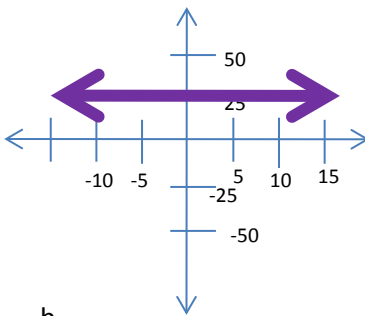

b.

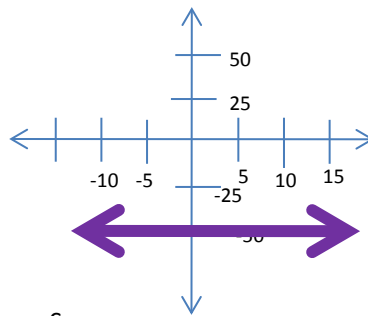

c.

Equation _____

Equation _____

Equation _____

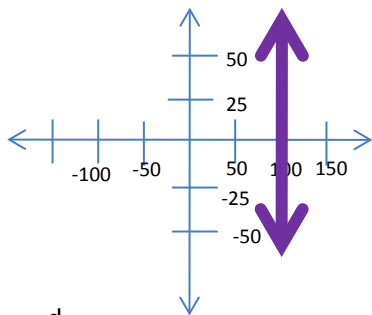

d.

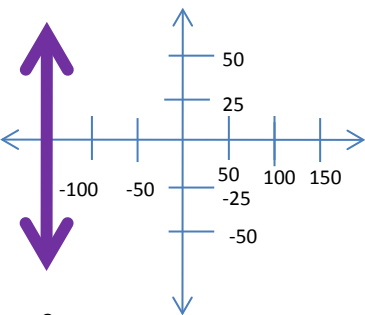

e.

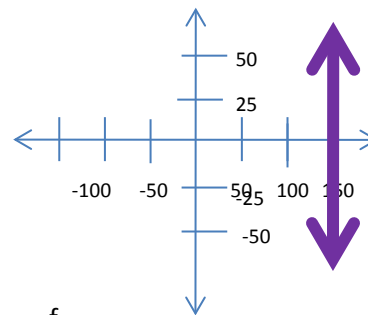

f.

Equation _____

Equation _____

Equation _____

Sketch the graph of the following lines.

2. $x = -3.4$

3. $x = \frac{2}{3}$

4. $y = -100$

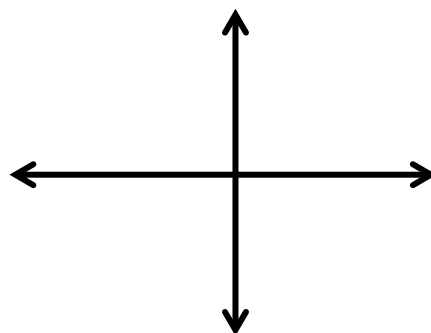
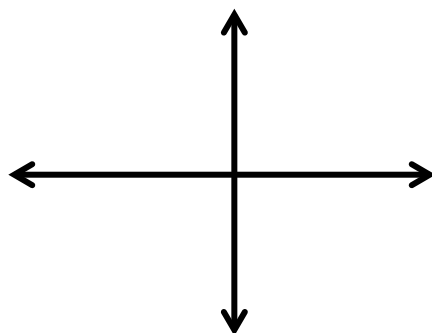
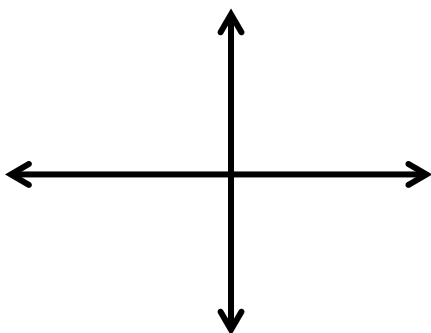

5. $y = 100$

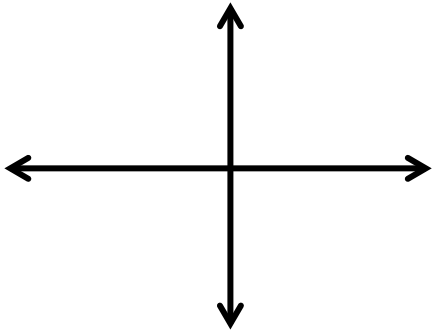

6. $y = 43.2$

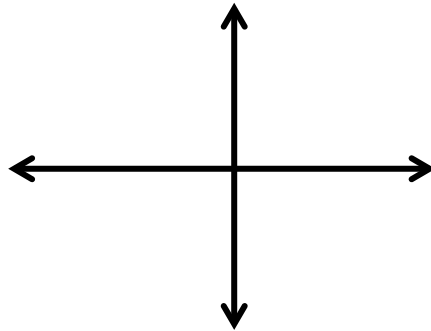

7. $y = -1.0001$

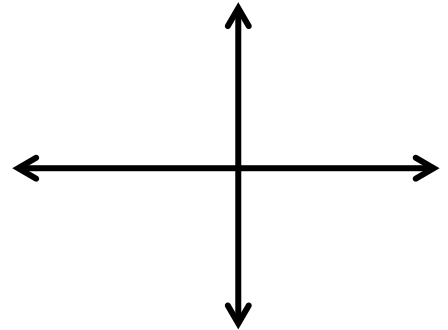

8. $y = -\frac{5}{7}$

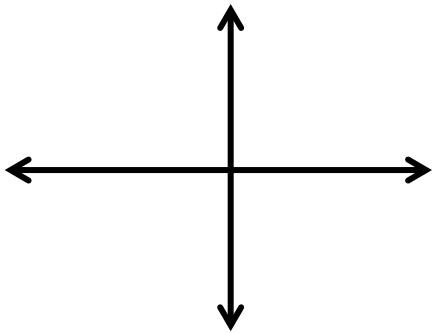

9. $x = 0$

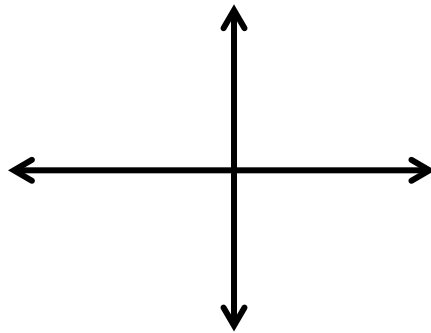

10. $y = 0$

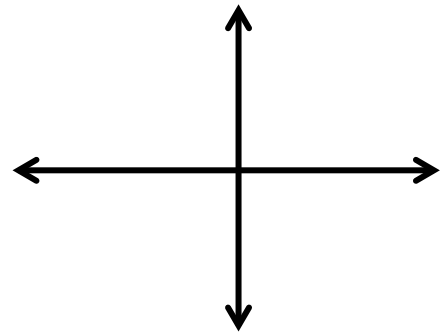

11. $x = 100$

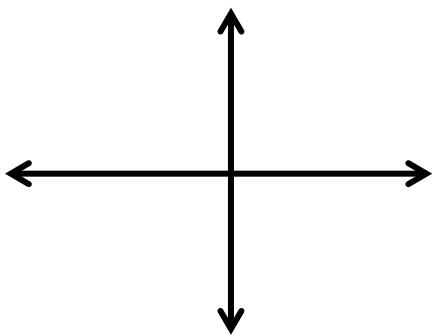

Video Log 4.3b

Sketch the graph of the following lines and then the lines that are perpendicular to them. Also, write down the equation of the lines that are perpendicular to them.

1. $y = -2x$

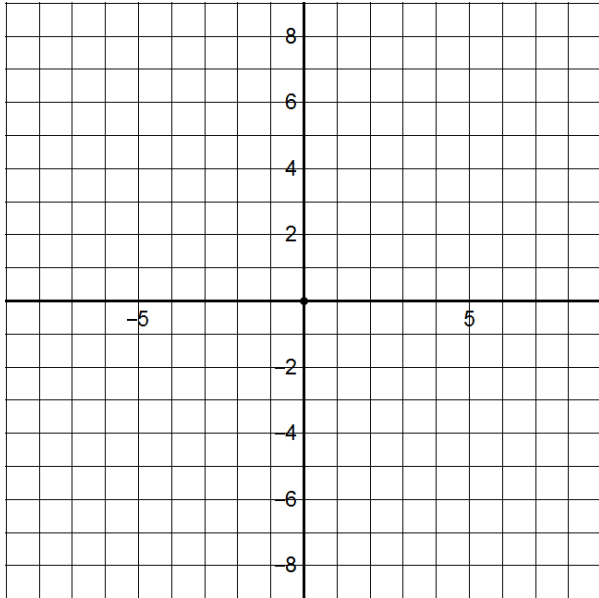

2. $y = \frac{2}{3}x$

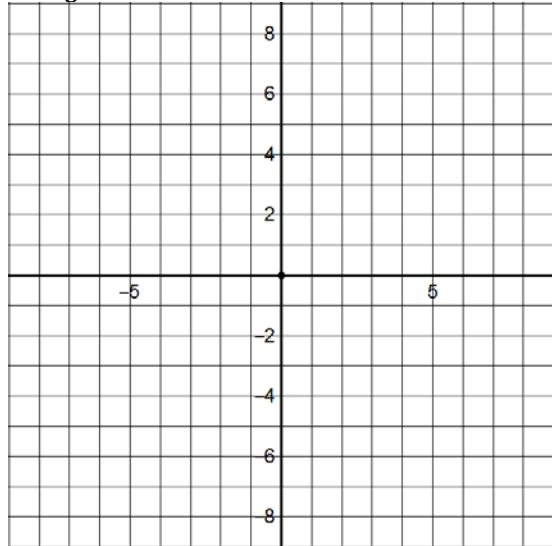

3. $y = -3x$

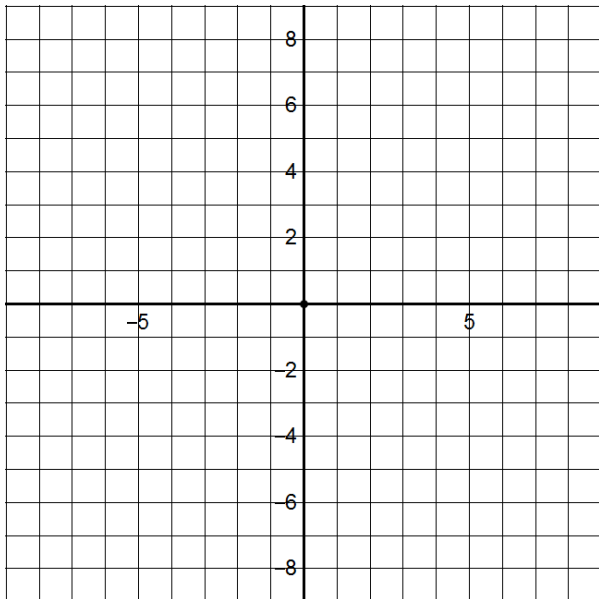

4. $y = \frac{1}{2}x$

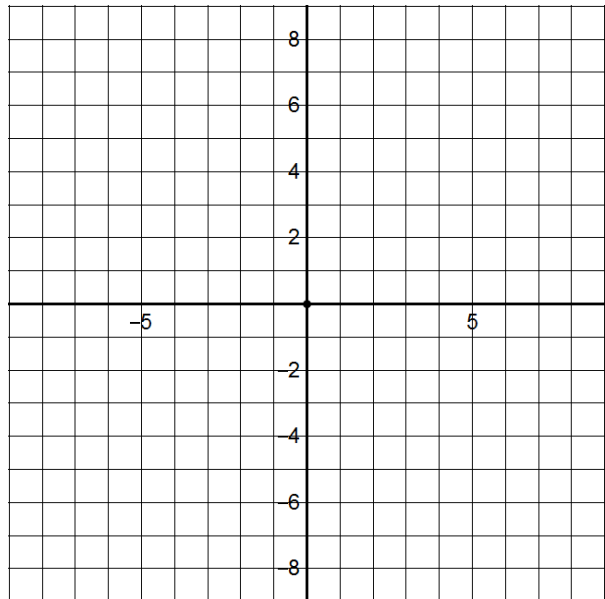

5. Find the equation of the lines in the graphs below and the lines that are perpendicular to them. Assume that all lines below pass through the origin $(0, 0)$

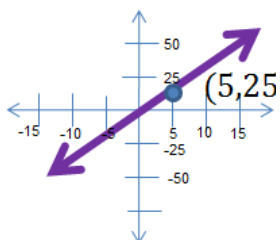

a.

Equation:

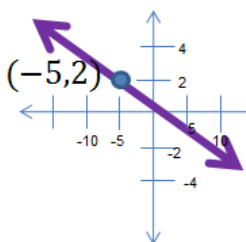

b.

Equation:

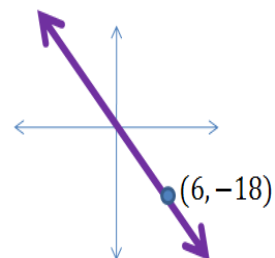

c.

Equation:

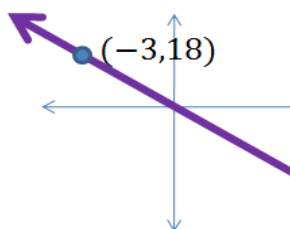

d.

Equation:

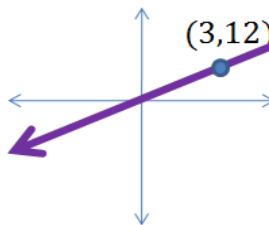

e.

Equation:

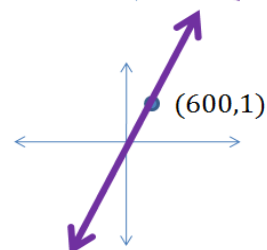

f.

Equation:

Video Log 4.3c

1. Are the points a, b, and c on the line $3x - 4y = 12$?
Explain your answer.

a. $(-3, 5)$

b. $(\frac{5}{3}, -\frac{7}{4})$

c. $(-\frac{1}{3}, \frac{3}{4})$

2. Sketch the graphs of the lines below

a. $y = 3 - x$

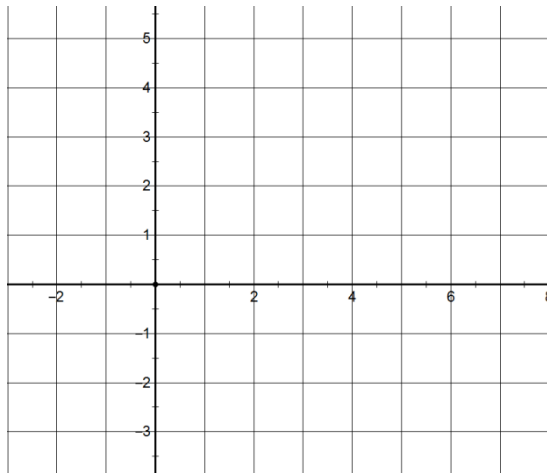

b. $y = 2x - 2$

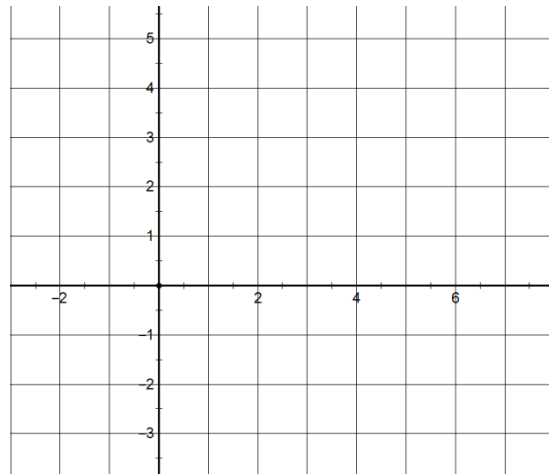

c. $3x - 4y = 12$

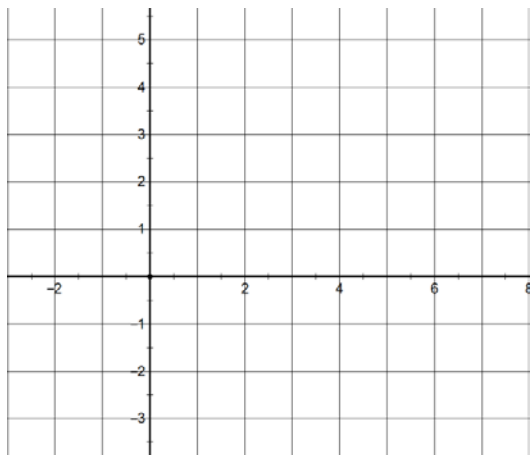

d. $3y + 4x = 2$

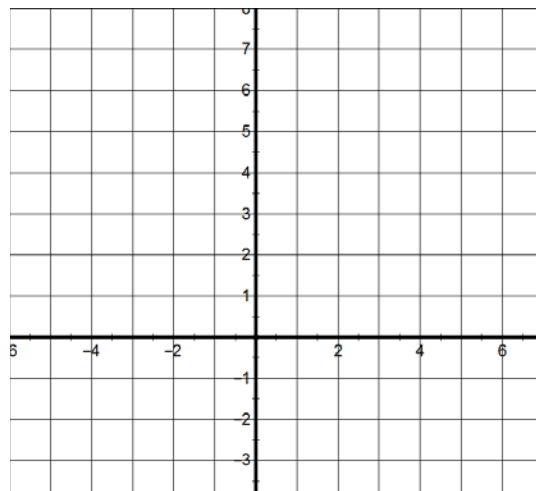

e. $2x - 3y = 6$

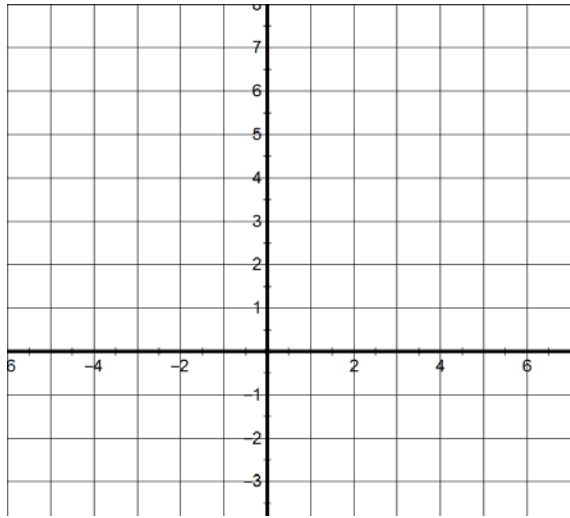

f. $x = 4$

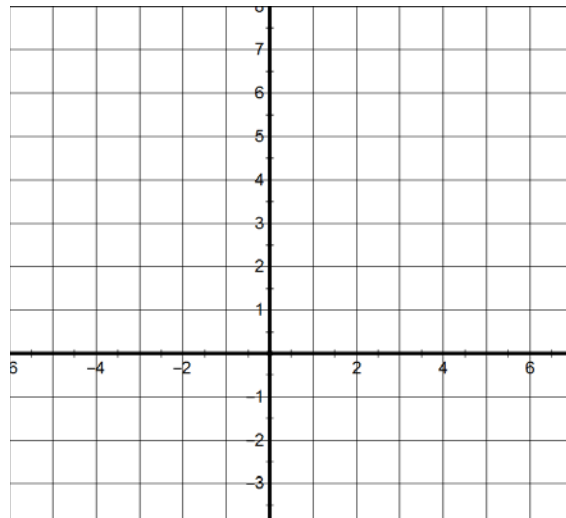

g. $y = -3$

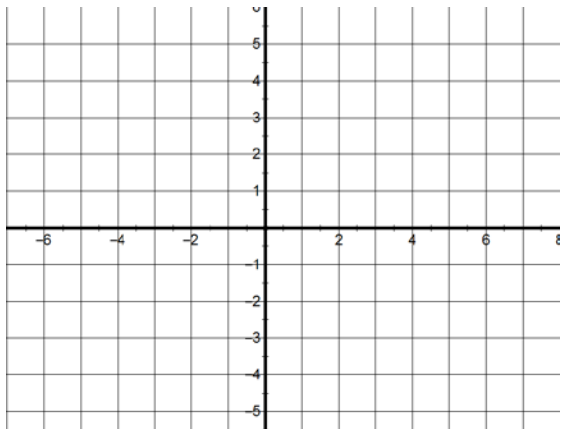

Video Log 4.3d

1. Sketch the graphs of solutions to the inequalities below.

a. $y \geq 3 - x$

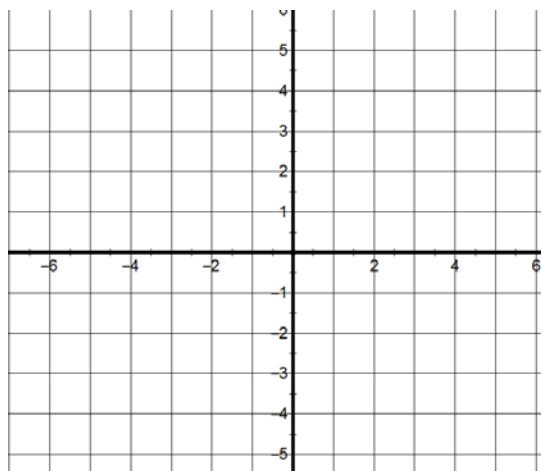

b. $y < 2x - 2$

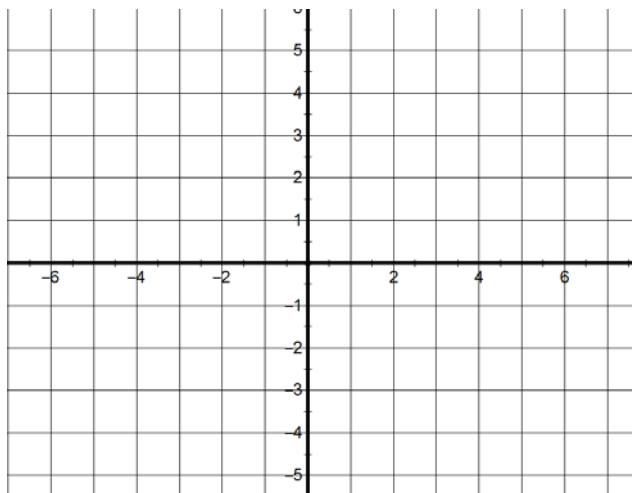

c. $2x - 3y \leq 6$

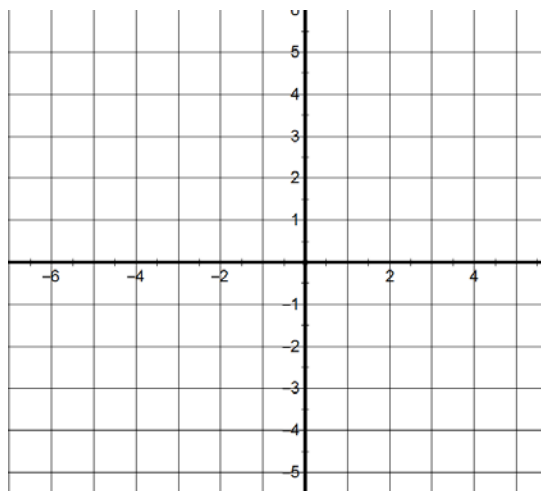

d. $x > 4$

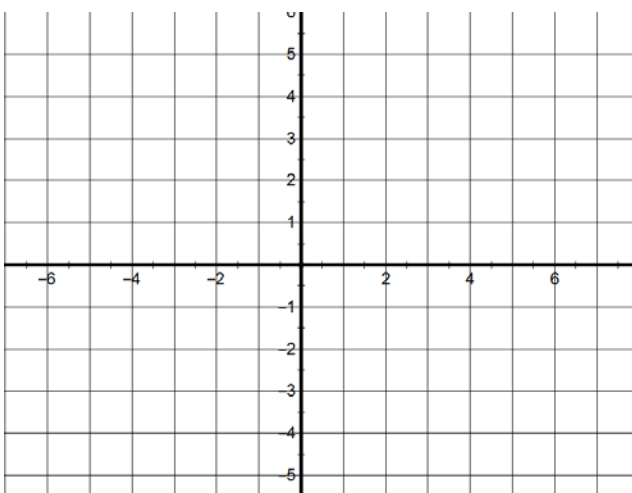

e. $y \leq -3$

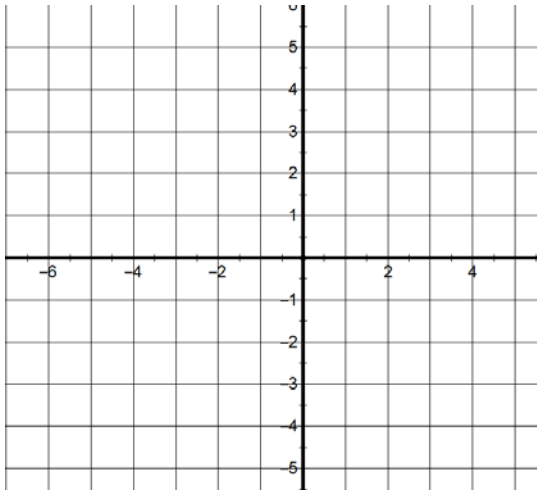

2. Find the coordinates of two points that are on the line, and of two points that are not on each line below.

a. $\frac{4}{5}x - \frac{2}{7}y = 11$

b. $-3(y - 2) + x = 5$

c. $-\frac{3}{2}(x - 4) + 1 = y$

d. $4x - 7y = 5$

3. Find the slope, x -intercept and y -intercept of each line below.

a. $3y - 2x = 7$

Slope: _____ x -intercept: _____ y -intercept : _____

b. $\frac{3}{5}x + 13 = y$

Slope: _____ x -intercept: _____ y -intercept : _____

c. $-\frac{3}{8}x + \frac{4}{5}y = 11$

Slope: _____ x -intercept: _____ y -intercept : _____

d. $\frac{2}{3}(y - 5) + x = 2$

Slope: _____ x -intercept: _____ y -intercept : _____

e. $y - 3 = 3\left(x - \frac{1}{2}\right)$

Slope: _____ x-intercept: _____ y-intercept : _____

4. Find the equations of the lines below.

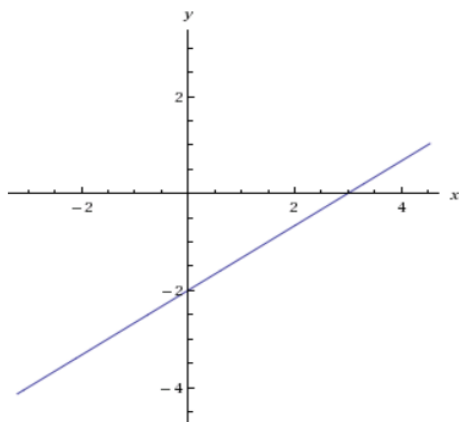

a.

Point on the line: _____

Slope of the line: _____

Equation of the line: _____

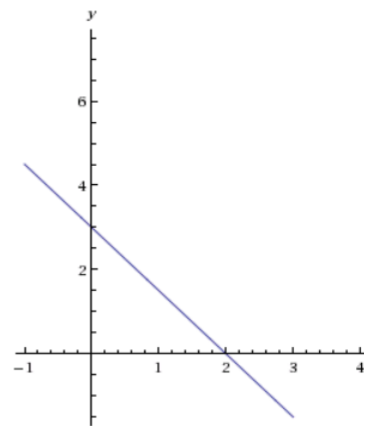

b.

Point on the line: _____

Slope of the line: _____

Equation of the line: _____

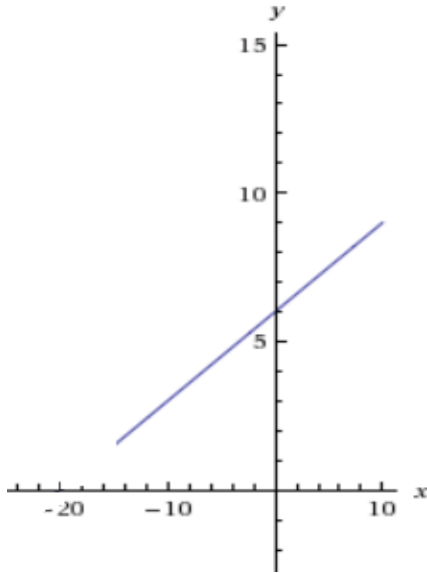

c.

Point on the line: _____

Slope of the line: _____

Equation of the line: _____

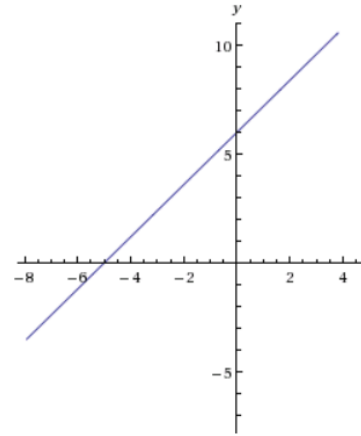

d.

Point on the line: _____

Slope of the line: _____

Equation of the line: _____

5. Find the equation of a line passing through the point $(-1, -4)$ and $(2, 7)$.

6. Find the equation of a line passing through the point $(2, -3)$ and slope of $-\frac{2}{3}$.

7. Find the equation of a line passing through the point $(-2,-5)$ and parallel to the line $y = 3x + 4$.

8. Find the equation of a line passing through the point $(-2,-5)$ and parallel to the line $y = -\frac{2}{3}x - \frac{11}{5}$.

9. Find the equation of a line passing through the point $(-2,-5)$ and having an x -intercept of $(\frac{4}{5}, 0)$.

10. Find the equation of a line passing through the point $(\frac{3}{4}, -\frac{1}{5})$ and perpendicular to the line $2y + 3x = 0$.

11. Find the equation of a line passing through the points $(-5, -9)$ and $(3,8)$.

12. Find the equation of a line passing through $(-3, 4)$ and perpendicular to the line $2y - 3x = 6$.

13. Find the equation of a line passing through the points $(-5, 1)$ and parallel to the line $2y = 3x - 4$.

14. Find the equation of a line that has slope of -3 and x -intercept of 4 .

15. Find the equation of a line that has slope of -3 and y -intercept of -5 .

Video Log 4.3e

Solve the systems of equations below. Use any method you think is suitable.

1.
$$\begin{cases} 5x - 2y = 6 \\ 5x + 3y = 2 \end{cases}$$

2.
$$\begin{cases} x - 2y = 6 \\ 5x + 7y = 2 \end{cases}$$

3.
$$\begin{cases} 7x = 2y + 6 \\ 5x + 11y = 2 \end{cases}$$

4.
$$\begin{cases} x - y = 6 \\ 5x + 9y = 2 \end{cases}$$

5.
$$\begin{cases} y = x - 6 \\ 2x + 3y = 2 \end{cases}$$

Sketch the graphs of the solution sets to the systems of inequalities below.

6.
$$\begin{cases} 5x - 2y > 7 \\ 5x + 3y \leq 2 \end{cases}$$

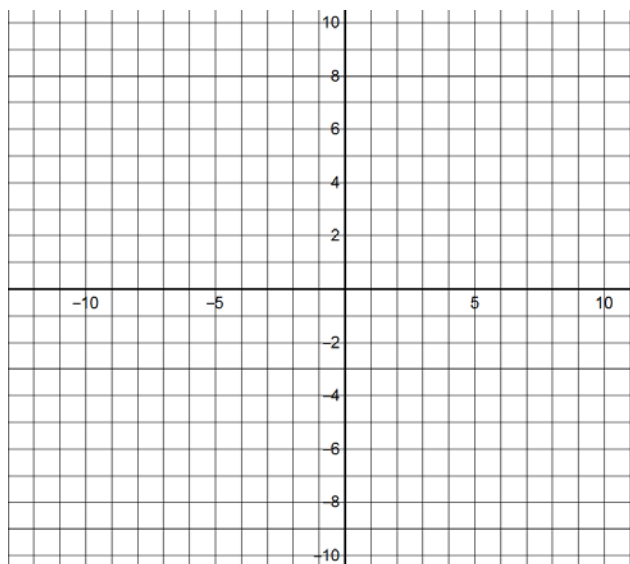

7.
$$\begin{cases} x - 2y < 5 \\ 4x + y < 2 \end{cases}$$

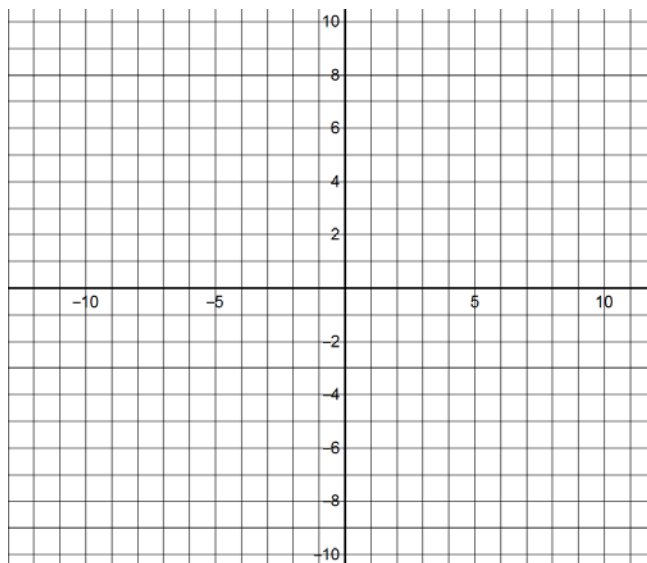

8.
$$\begin{cases} 7x \geq 2y + 7 \\ 5x + y < 2 \end{cases}$$

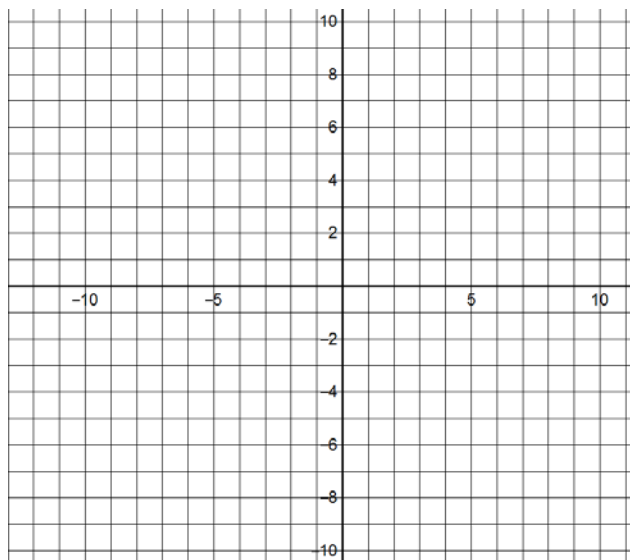

9.
$$\begin{cases} x - y \leq 6 \\ 5x + 9y \geq 2 \end{cases}$$

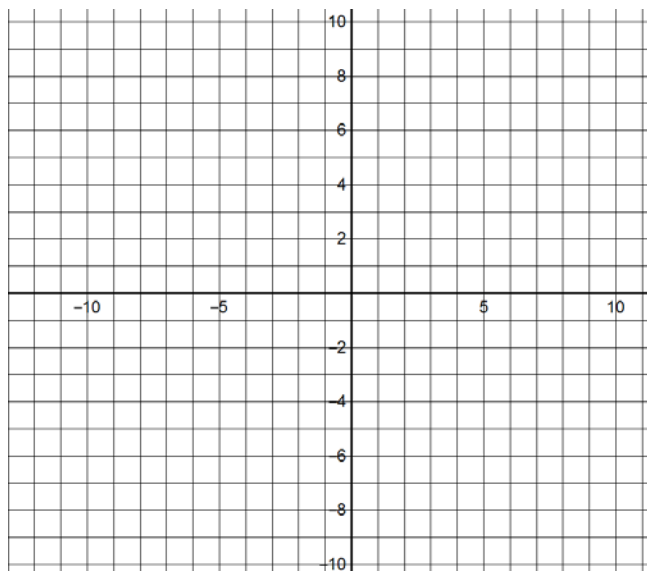

10.
$$\begin{cases} y \geq x - 6 \\ 2x + 3y \leq 2 \end{cases}$$

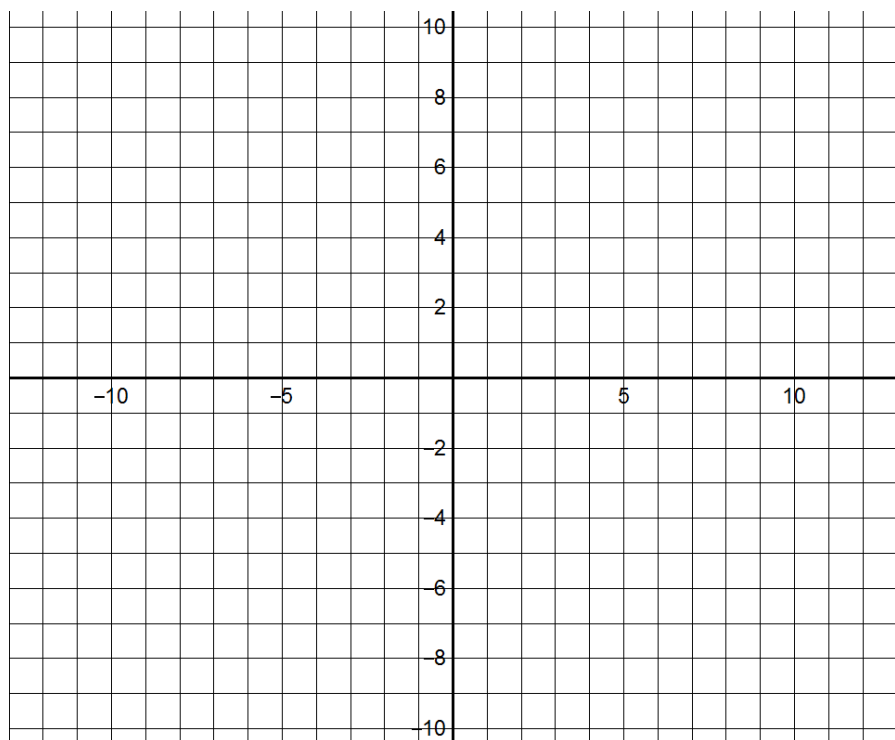

4.4 Interpreting Graphs and Linear Models

Lecture

Applications of lines and graphs Reading Graphs <http://www.youtube.com/watch?v=plhuVnNFYxc> (7 min, , video Log 4.4a)

Linear Models http://www.youtube.com/watch?v=8DXMehKa6_w (11 min, video Log 4.4b)

Applications <http://www.youtube.com/watch?v=idPmgnUD-X0> (8 min, video Log 4.4c)

1. Please include a **summary** and **your detailed notes** from the lectures or e-text reading of this section. Failure to provide a summary and your notes could result in receiving a zero for this section.
2. List all the questions you had while watching the lectures or reading the e-text pages for this section. Do not just say “everything,” but please be specific and elaborate.
3. List all the video log questions on which you were stuck for this section. Do not just say “all,” but please be specific. Make sure you have attempted all the video log questions. You do not have to get them all correct. The attempt is what is important.
4. If using ALEKS, list all the topics on which you would like help.

Video Log 4.4a

1. The graph to the right represents height of a plant in the last 10 weeks.

a. In week 4 what is the plant height in centimeters?

b. In what week was the plant height about 15 cm?

c. What is the maximum expected plant height reached by this plant?

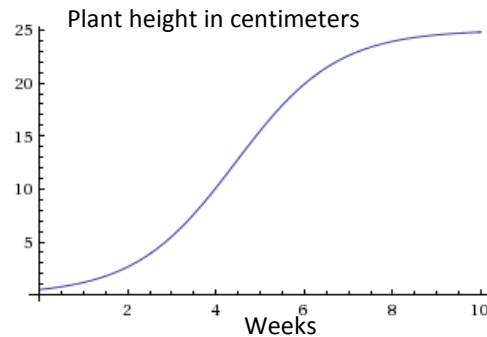

d. In what weeks was the height of the plant between 10 and 15 cms?

e. What was the range of the plant height for days between week 6 and week 10?

2. The graph to the right indicates the use of corn for animal feed, food export and for ethanol fuel production in the U.S.

a. Estimate the total millions of tons of corn use in the years 1990, 1995, 2000, 2005 and 2010.

b. What is the trend for the total corn production over this 20 year period?

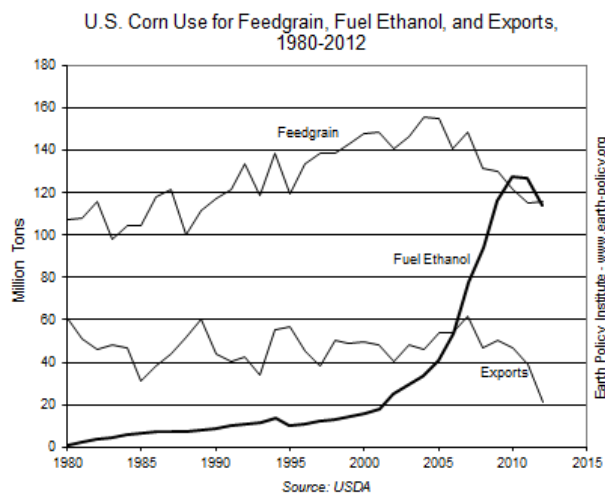

c. Can you explain the steep drop in corn exports over the past 5 years?

3. The graph below shows the revenue from selling a commodity in millions of dollars with respect to the selling price in dollars of the commodity.



- What is revenue when the price is set at 10\$/unit?
- What should the unit price be set at to maximize the revenue?
- What unit price(s) of the commodity will generate \$800,000,000 in revenue?
- What unit price range which will generate more than \$800,000,000 in revenue?

Video Log 4.4b

1. A plant growth formula is given by the linear equation $y = \frac{5}{3}t + 4$, where y =height in inches and t =number of weeks. What is the height of the plant in the 3rd week?
2. **Let the amount of water in a leaking bucket be given by $A = 8 - 0.25t$, where A =amount of water in bucket in liters and t = time in minutes after it began leaking.**
 - a. How much water is in the bucket after 5 minutes?
 - b. How much water was in the bucket at the beginning after it started leaking?
 - c. When will the bucket be completely empty?
 - d. What is the t -intercept and the A -intercept? What is the significance of these intercepts?
 - e. What is the slope of this line? What is the physical significance of the slope?
3. **Suppose Anu has a phone card and the amount of money left on the card is given by $B = 37.30 - 0.02x$ where B =balance of money left on Anu's card after x minutes of call.**
 - a. What is the rate Anu is paying per minute on her phone card.
 - b. How much money is on Anu's card after talking to her sister for 2 hours and 5 minutes?
 - c. What is the physical significance of the slope?
 - d. What is the maximum number of minutes Anu can talk using her card? How many hours is it?

4. Linda's parents loaned her 12,345 dollars interest free for her college tuition and books. Linda promised to pay her parents back 80 dollars a week until the loan is completely paid off. How long will it take Linda to pay her parents back? Write an equation that will allow Linda a quick overview of how much money she owes her parents in a particular week before it is all paid off

5. Suppose that the growth of a plant is charted as shown below.

a. Determine what height the plant will be in 2 weeks.

b. If you assume a linear growth rate, what is the relationship between time t in days and the height h of the plant measured in inches?

c. In how many days will the plant reach a height of 2 feet?

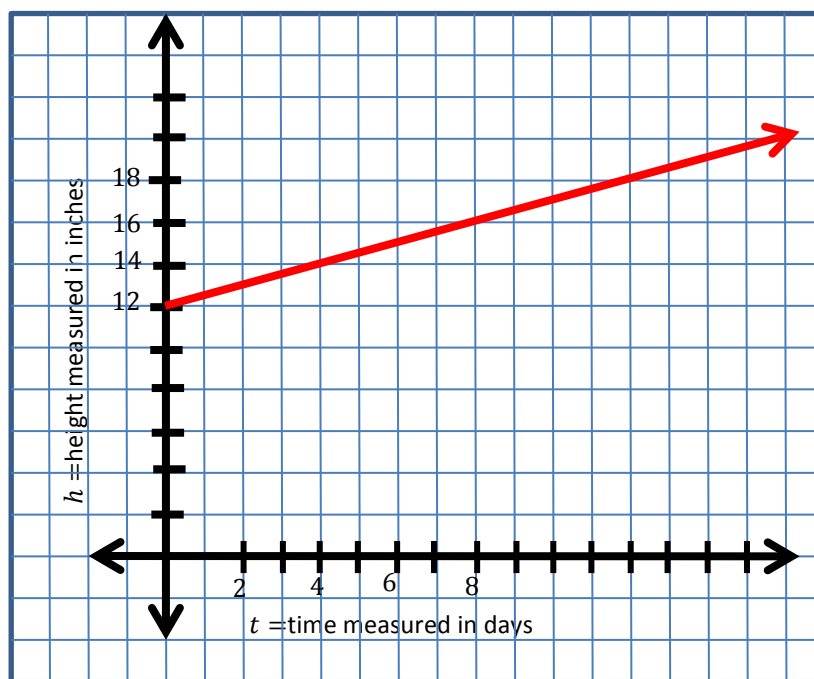

6. In 2000 the population of India was 1014 million people. In 2010 its population was 1170 million people (Almost four times as many people as in the U.S.)

a. Find a linear equation that fits the above data where y is India's population in millions in the year x .

b. Use the equation in (a.) to predict India's population in 2025.

c. Explain the meaning of the slope of the line in (a.).

Video Log 4.4c

1. The graph below is of the Wisconsin population over the past twenty five years.
 - a. Draw a line that seems to fit this population trend.
 - b. Estimate from your line in (a.) when the population will reach 6 six million.
 - c. Select two points from your line in (a.) (approximately) to determine the slope of the line and interpret the meaning of this slope.
 - d. Find an equation of the line using the slope from (c.) and one of the points selected.
 - e. From your equation determine when the population will reach 6,000,000 and compare with your answer in (b.)

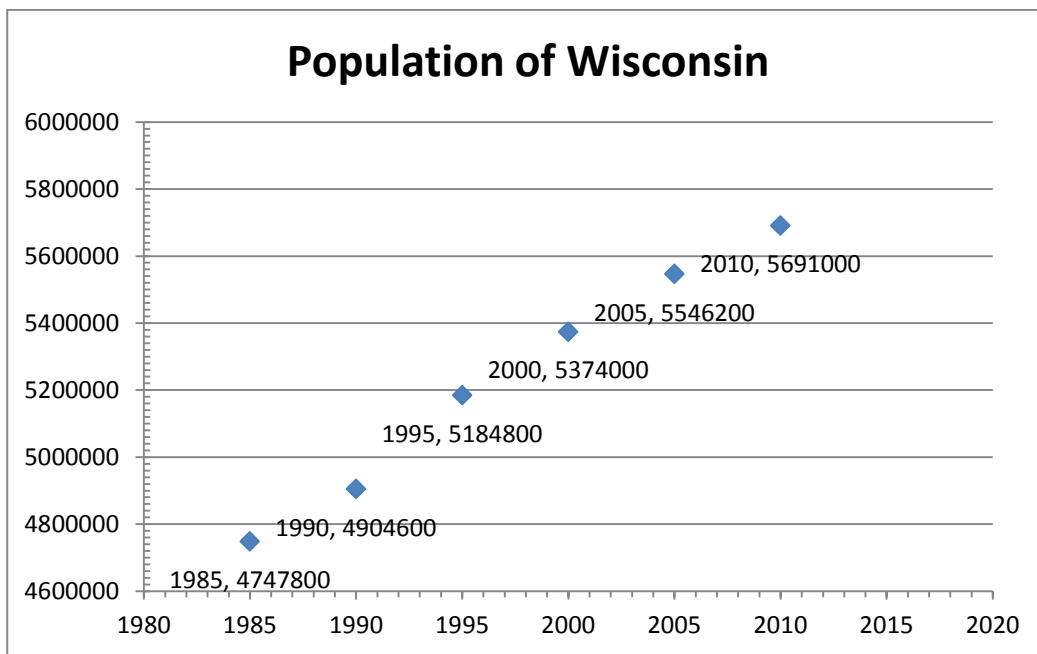

2. **A campus club sells cupcakes each Monday as a fundraiser. They play around with pricing to see how the demand for cupcakes depends on the selling price. When they charge \$0.65 per cupcake, they notice that on average they sell 135 cupcakes each Monday, but when the price was set at a \$0.75 per cupcake, they sold 80 cupcakes each Monday. They purchase their cupcakes in bulk from a local bakery for \$0.25 each.**
- Find a linear demand relation $y = p(x) = mx + b$ that fits the data given, i.e. $(135, 0.65), (80, 0.75)$ where x is the number of cupcakes that will sell and y is the selling price.
 - Find the revenue function $y = R(x) = x \cdot p(x)$, that gives the total revenue from selling x cupcakes.
 - Give the cost function $y = C(x)$ that gives the total cost for buying x cupcakes from the local bakery.
 - Use b and c to state the net profit function $y = P(x)$ obtained each week when x cupcakes are sold.
 - Plot the profit function at <http://www.wolframalpha.com/examples/PlottingAndGraphics.html> for sales between 0 and 180 cupcakes per week and estimate the number of cupcakes to sell to make the profit as large as possible.

3. A local fundraising event for student scholarships involves volunteer chefs who provide a variety of food samples for an evening event that charges admission. The organizing committee wants to optimize revenue and has data from two years on total number of tickets sold and the ticket price. In the first year when the ticket price was \$30 per person, 350 tickets were sold. The next year, the price was \$40, and 270 tickets were sold.
- Plot the information above where the x -coordinate represents total number of tickets sold and the y -coordinate the price per ticket.
 - Assuming there is a linear relation between x and y , find the equation $y = mx + b$.
 - Use your equation in (b) to predict the total number of tickets sold when the ticket price is set at $y = \$20, \$25, \$30, \$35, \$40, \45 and $\$50$.
 - For each price in (c.) compute the revenue by multiplying the price by the corresponding number of ticket sales.
 - Plot the set of points in (d.) as (ticket price, total revenue) and from your plot estimate what ticket price will generate the maximum revenue. Also use your equation from (b.) to determine how many tickets would sell at this price.
4. **Two cell phones offer the rates below for one year of service. Touchphone charges \$60 plus 7 cents a minute for all calls. BT&U charges \$80 a year plus 5 cents a minute for calls.**
- Find linear equations for each provider $y = mx + b$ where y is the total cost for a year of service and x is the number of minutes of calls.
 - Plot both lines and determine for how many minutes a year the Touchphone plan is cheaper.

4.5 Other Applications

Lecture

Applications <http://www.youtube.com/watch?v=WXLZKrZUnKQ> (14 min, video Log 4.5a)

Applications <http://www.youtube.com/watch?v=dsbrQ54So38> (7 min, video Log 4.5a)

Applications <http://www.youtube.com/watch?v=CZQu8Q3maEk> (11 min, video Log 4.5b)

1. Please include a **summary** and **your detailed notes** from the lectures or e-text reading of this section. Failure to provide a summary and your notes could result in receiving a zero for this section.
2. List all the questions you had while watching the lectures or reading the e-text pages for this section. Do not just say “everything,” but please be specific and elaborate.
3. List all the video log questions on which you were stuck for this section. Do not just say “all,” but please be specific. Make sure you have attempted all the video log questions. You do not have to get them all correct. The attempt is what is important.
4. If using ALEKS, list all the topics on which you would like help.

Video Log 4.5a

- 1. A recipe calls for $1\frac{1}{3}$ cups of flour, $\frac{1}{2}$ c sugar and 1 stick of butter. It is critical that these proportions be adhered in order for the cookies to turn out well. Anu was careless as she started and put in 2 cups of flour instead of the $1\frac{1}{3}$ cups and had added the sugar before realizing her error. Determine how much additional sugar and how much total butter she should add to keep the proportions in line with the recipe.**

- 2. Consider the situation where you need to make a large volume of punch using pineapple juice, passion fruit juice and sprite with the volume ratio of 2:3:2. You have already mixed together 3 gallons of pineapple juice and 4 gallons of passion fruit juice and 2 gallons of sprite. Determine the minimum amount of two of the ingredients that you should add to keep the correct volume ratio of the three ingredients.**

- 3. The sum of three consecutive even integers is 96. What are the three numbers?**

- 4. Kim's Prepaid phone card started with a \$90 balance and each minute of call time costs 12 cents. Determine how many minutes of calls she had made when her balance had decreased to \$39.**

5. A rectangular swimming pool is 10 meters longer than twice its width. Determine the dimensions of the pool if the perimeter of the pool is 140 meters.
6. Jim's salary increased from \$45,359 to \$48,234 from 2012 to 2013.
- What was the dollar value of the increase?
 - What percentage did Jim's salary increase by?
 - What percent smaller was his salary in 2012 compared to 2013?
7. **A new school server hard-drive has a capacity of 16,000 gigabytes and needs to provide storage space for 134 staff members. Determine how many gigabytes of server space is available for each staff member.**
8. John earns \$64,000 a year and pays 27% of his salary in income tax. How much income tax does he pay?
9. A pair of \$120 shoes was marked down 45%. What was the sale price? Use a diagram to show your answer.

7. Larry and Mary work part time. Larry makes \$9/hr and Mary \$10.50/hr. During a certain week they earned a total of \$414 and they worked a total of 42 hours. How many hours did each of them work?
8. A bag of chips and 12pack of soda costs \$11. The soda was \$3.20 more than the chips. Determine the cost of the chips and of the soda.
9. How many liters each of 12 molar hydrochloric acid and 4 molar hydrochloric acid should be mixed to make 2.8 liters of 6 molar hydrochloric acid.

4.6 Rate Problems

Lecture

 Rate Problems <http://www.youtube.com/watch?v=prwMJfjTD24> (11 min, video Log 4.6a, video Log 4.6b)

1. Please include a **summary** and **your detailed notes** from the lectures or e-text reading of this section. Failure to provide a summary and your notes could result in receiving a zero for this section.
2. List all the questions you had while watching the lectures or reading the e-text pages for this section. Do not just say “everything,” but please be specific and elaborate.

3. List all the video log questions on which you were stuck for this section. Do not just say “all,” but please be specific. Make sure you have attempted all the video log questions. You do not have to get them all correct. The attempt is what is important.

4. If using ALEKS, list all the topics on which you would like help.

Video Log 4.6a

1. How long does it take to travel from Madison, WI, to Minneapolis, MN which is 245 miles away when travelling at 60 mph?
2. What is the speed of spread of the emerald ash borer in $\frac{mi}{month}$ if it has spread 150 miles over three years?
3. Determine how many years it would take a spaceship going 25000mph to travel to our nearest non-sun star which is 2.5×10^{13} *mi* from Earth.
4. Paul and Sarah plan to meet for a week-long camping trip. Paul lives in WI and Sarah lives 1500 miles away in NM. They plan to drive and camp wherever they meet. Paul drives at 60 mph and Sarah is a bit of a lead-foot and drives at 75 mph. Paul is an early riser and leaves WI at 6:00AM. Sarah starts at 9:30AM. Determine at what time they will meet and how far from WI the meeting place is.

5. A bicyclist traveled 45 miles in 3 hours against the wind and 57 miles in the same time with the wind. Find the speed of the bicyclist in still air and the speed of the wind.

6. A kayaker can paddle 5 miles upstream in the Yukon river in 2 hours, and 11 miles downstream in 2 hours. Determine the speed of the current and how fast the kayaker can paddle in still water.

Video Log 4.6b

1. Max and Paul can pick 6 and 8 pints of strawberries per hour, respectively. How long would it take them to pick 30 pints when working together?

2. **A newsletter printing job needs to be done each week. Using an older copy machine the job took 2.5 hours to complete. Then a new machine was brought in and using both machines, the job could be completed in 1 hour. Determine how long it would take the new machine to do the job alone.**

3. The elephants at a zoo eat a large bale of hay every 5 days. The zebras eat a large bale of hay every three weeks. If these are the only animals at the zoo eating hay, how long will 15 large bales of hay last?

4. It takes 15 hours for a water hose from Jim's house to fill his small backyard pool. One year his neighbor offers to help out with a hose from his house. That year, it took only 10 hours to fill the pool. Determine how long it would take to fill the pool using only the neighbor's hose.

5. **An older machine can fill 20,000 soda cans per hour. A new machine can fill 35,000 soda cans per hour. How long with it take to fill 6,000,000 soda cans if we use both machines?**

4.7 Using Formulas from a variety of fields

Lecture

📺 Applications <http://www.youtube.com/watch?v=ys0RRfBJ7HU> (10 min, video Log 4.7a)

1. Please include a **summary** and **your detailed notes** from the lectures or e-text reading of this section. Failure to provide a summary and your notes could result in receiving a zero for this section.
2. List all the questions you had while watching the lectures or reading the e-text pages for this section. Do not just say “everything,” but please be specific and elaborate.
3. List all the video log questions on which you were stuck for this section. Do not just say “all,” but please be specific. Make sure you have attempted all the video log questions. You do not have to get them all correct. The attempt is what is important.
4. If using ALEKS, list all the topics on which you would like help.

3. $\frac{1}{f} = \frac{1}{f_1} + \frac{1}{f_2}$, solve for f_1 .

4. $E = mc^2$, solve for c .

5. $F = ma$, solve for m .